

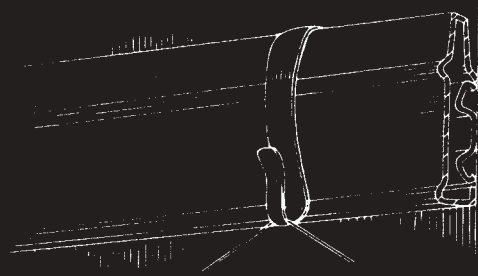

SECTION FOUR

- **PICTURE MOULDINGS**
- **WIRE MOULDINGS**
- **CORNICES**
- **HANDRAILS**
- **CAP MOULDINGS**
- **CHAIR RAILS**

Examples of cornice combinations are illustrated on page 76.
Others can be created by using different tooling combinations.



1333

PICTURE
MOULDING

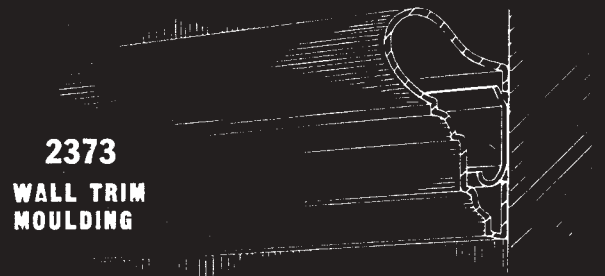

2373

WALL TRIM
MOULDING

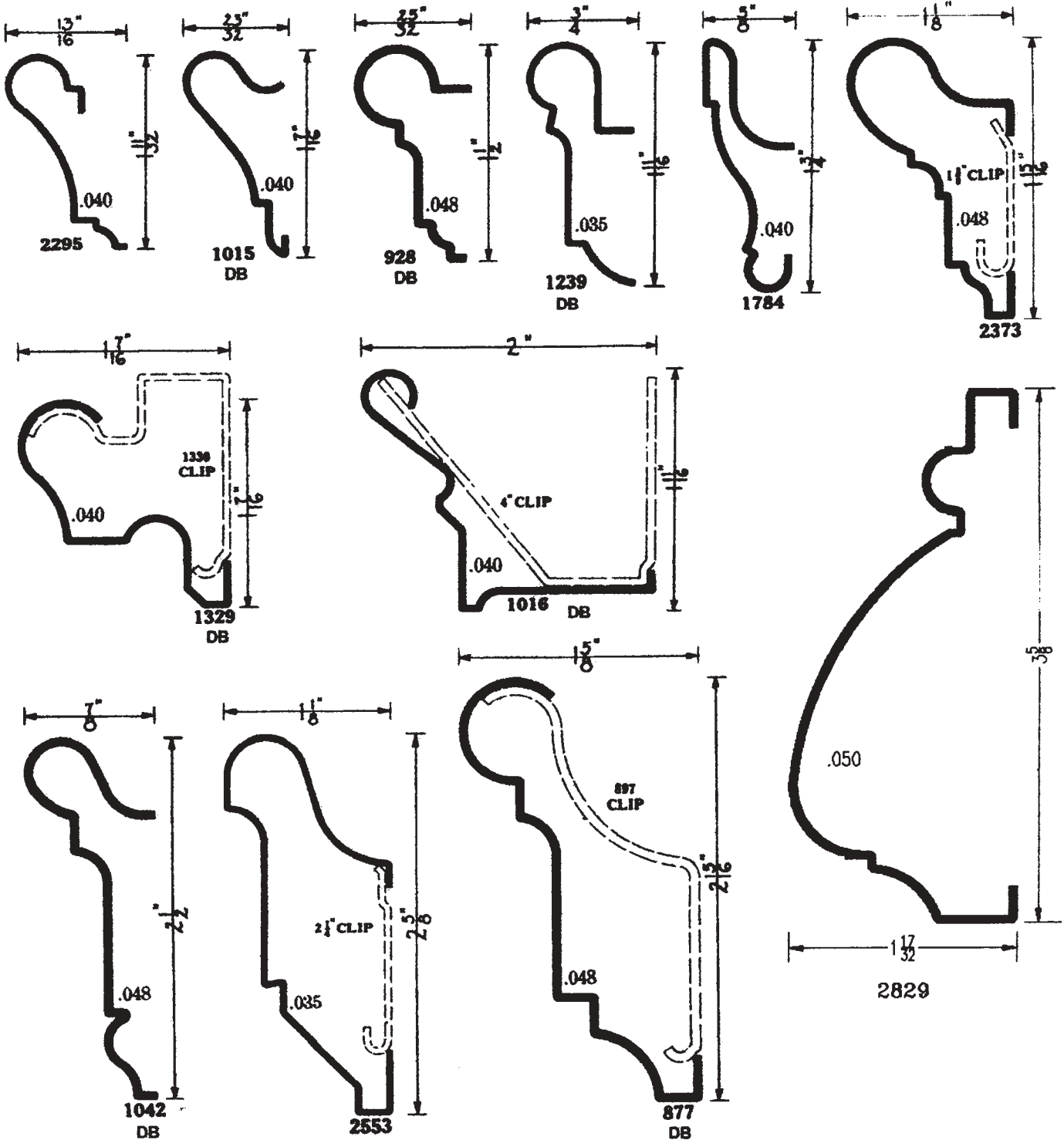

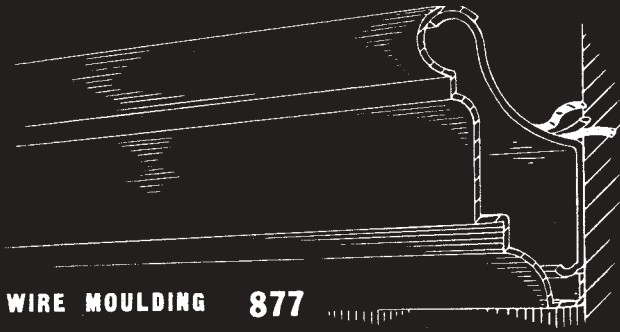

WIRE MOULDING 877

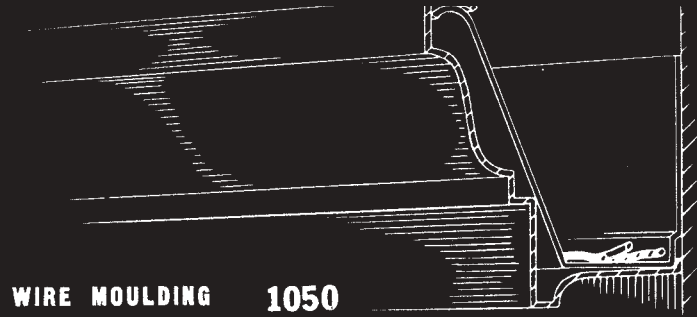

WIRE MOULDING 1050

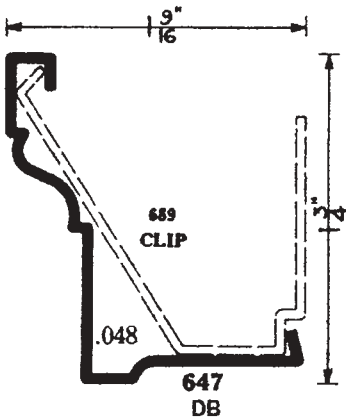
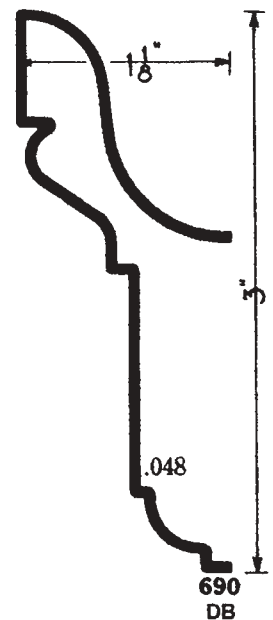
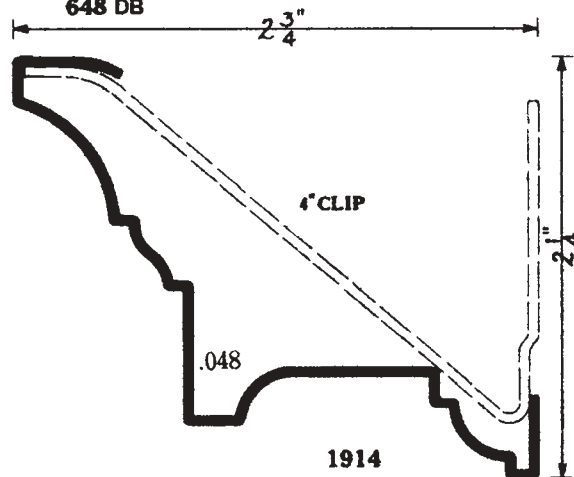
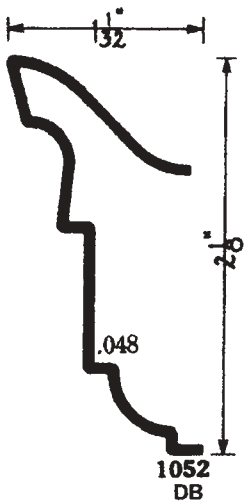
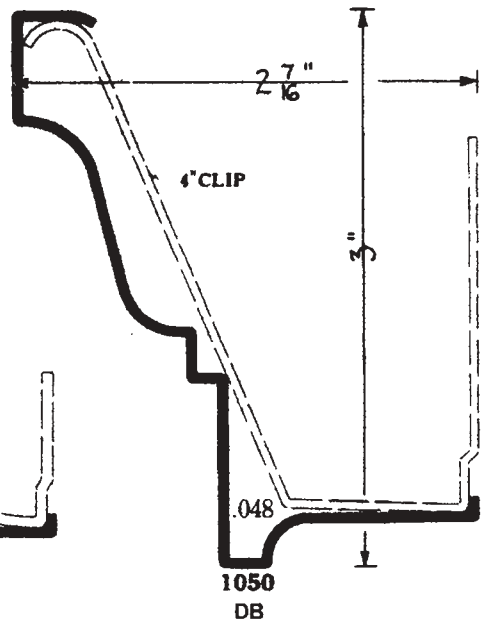
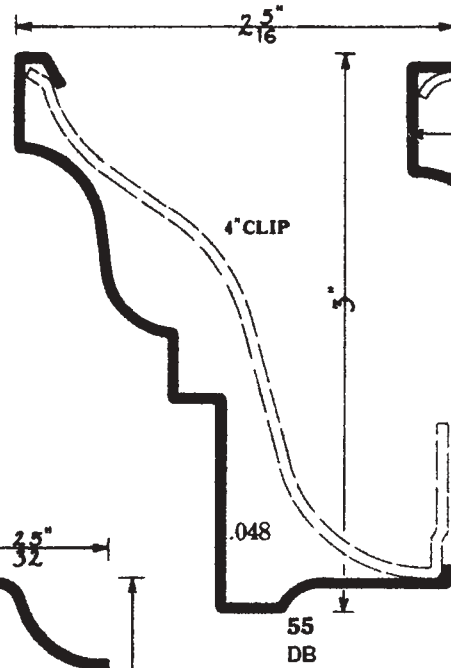
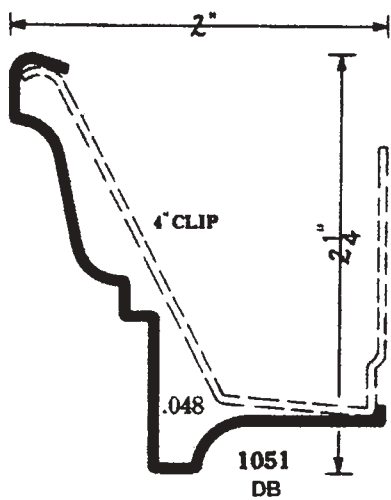

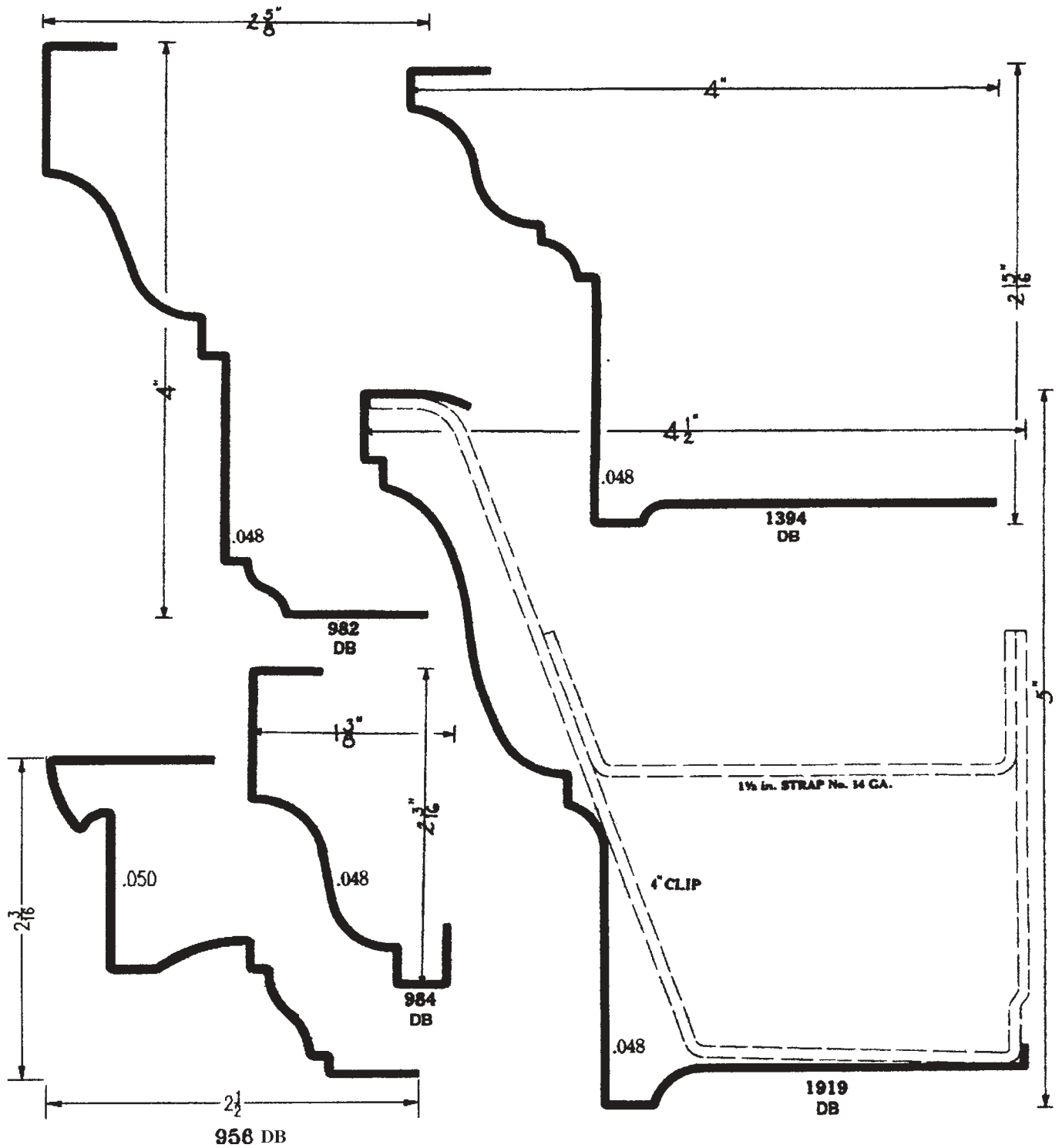
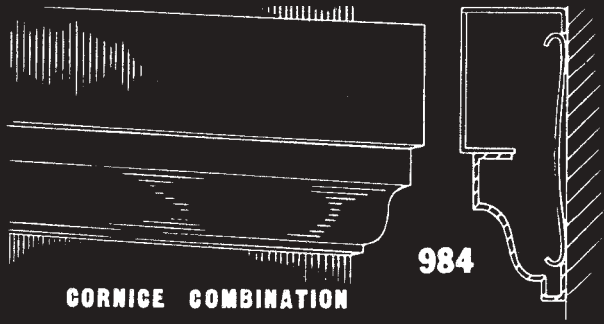

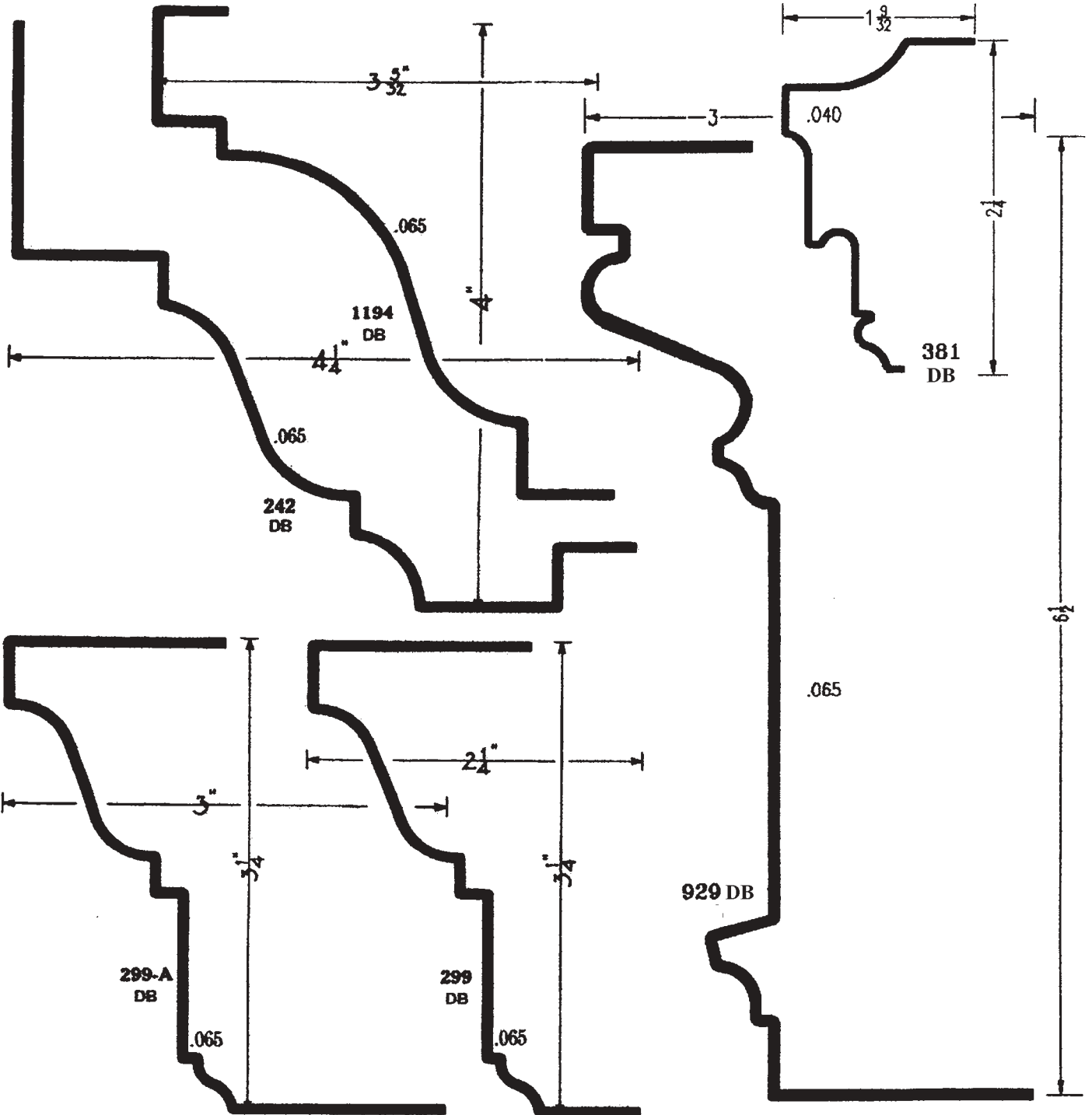
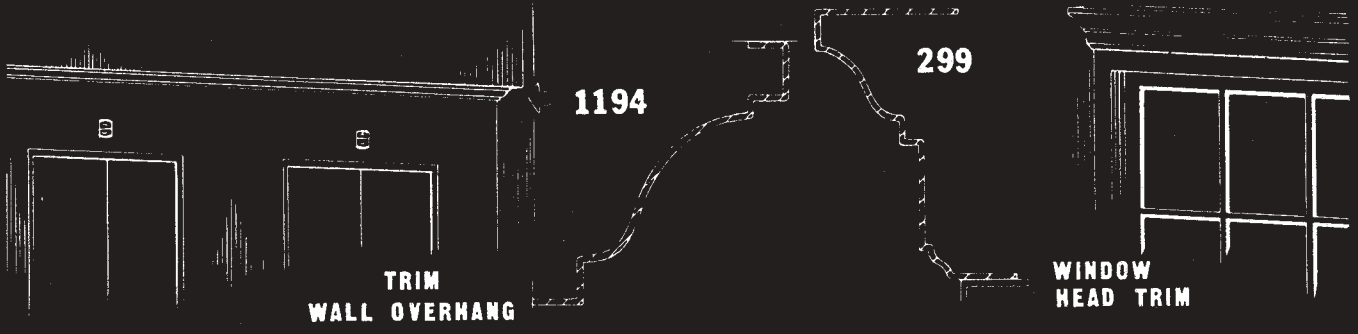

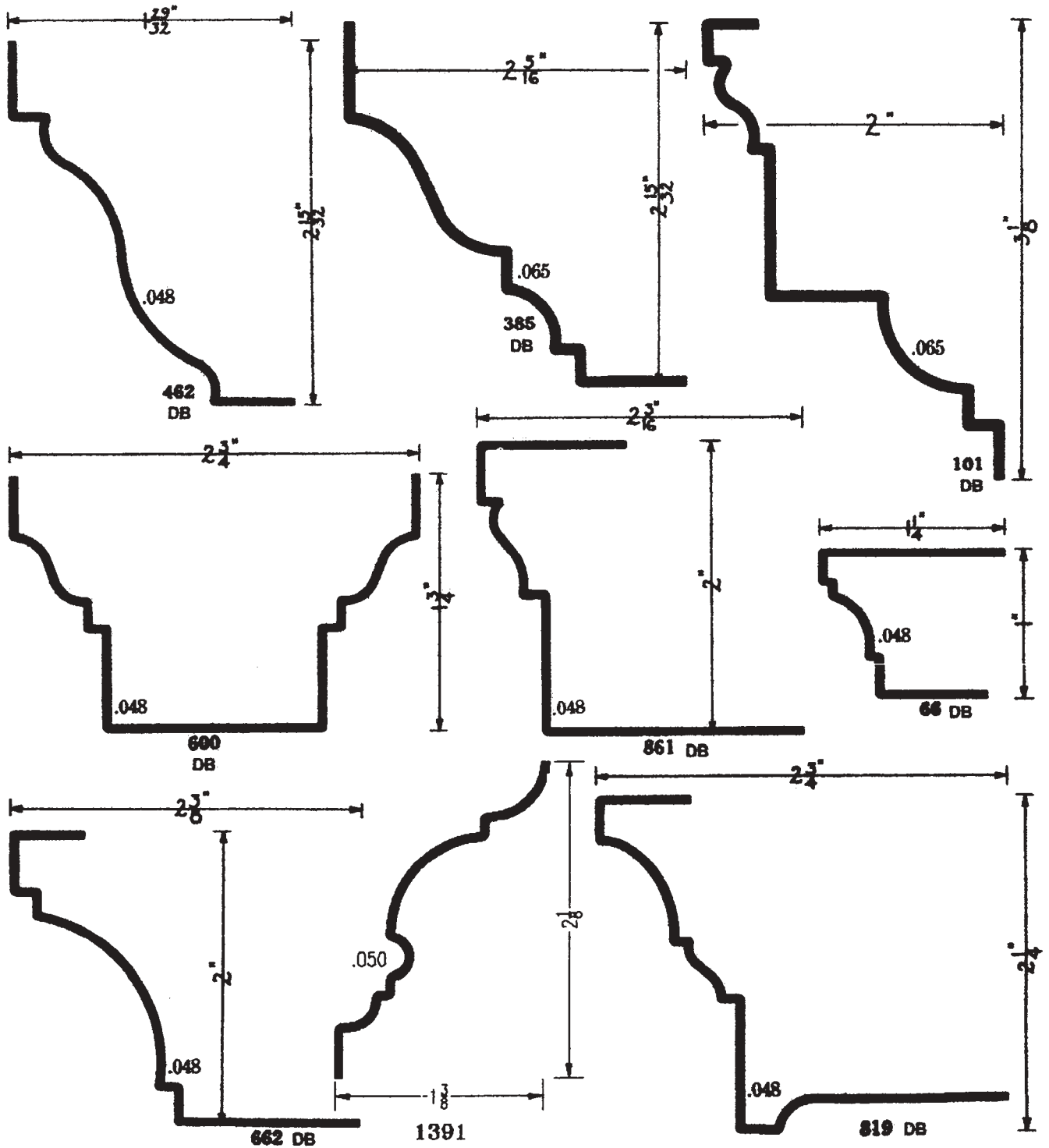
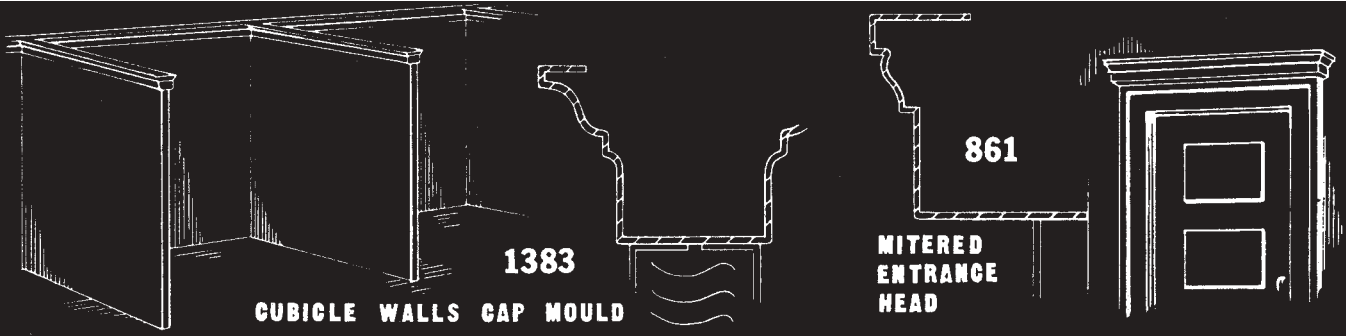

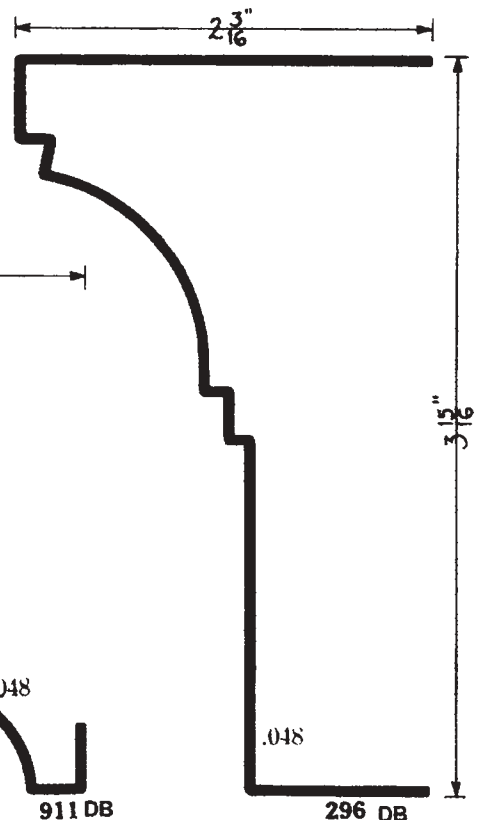
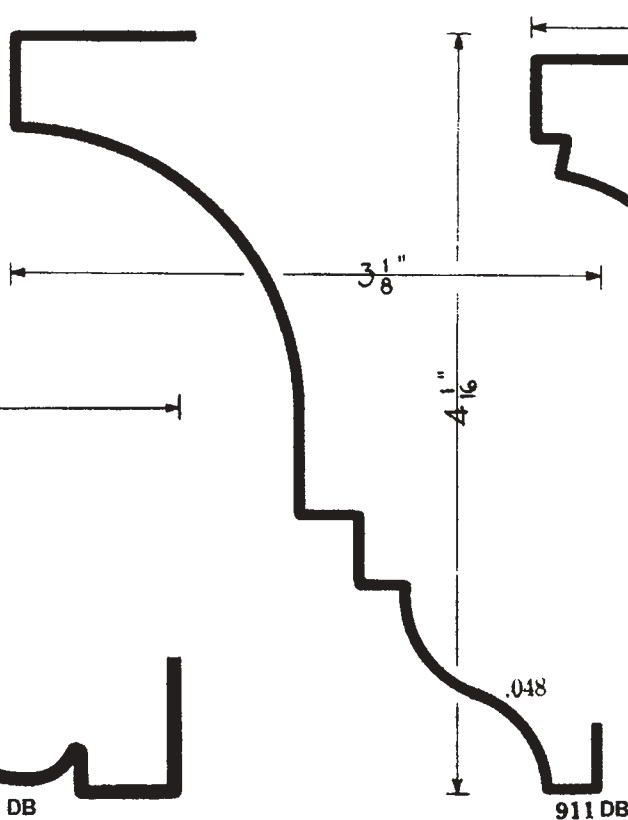
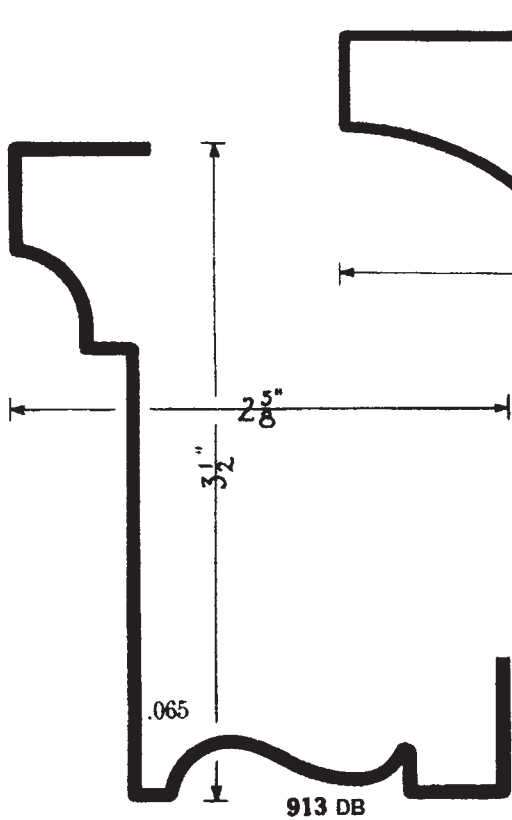
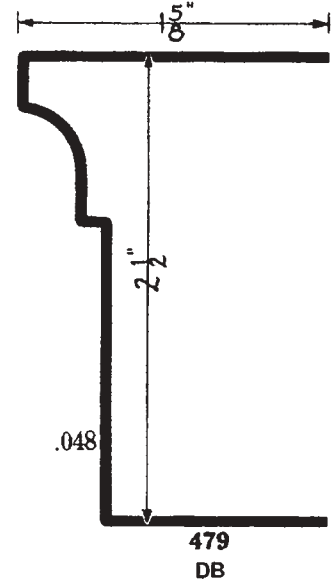
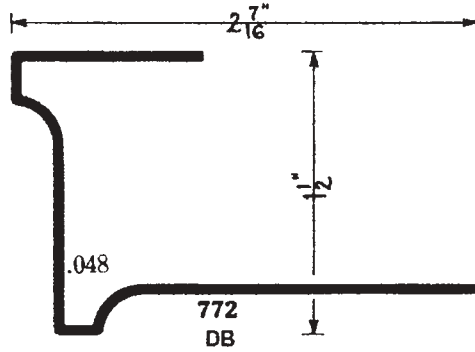
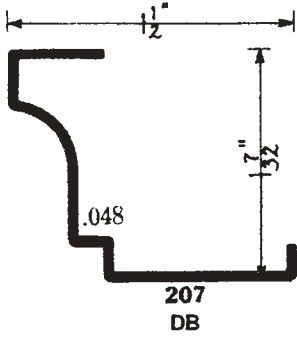

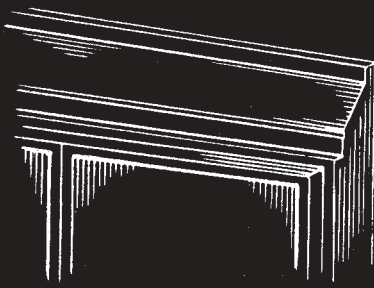

2253
RECESSED
HEAD BAND

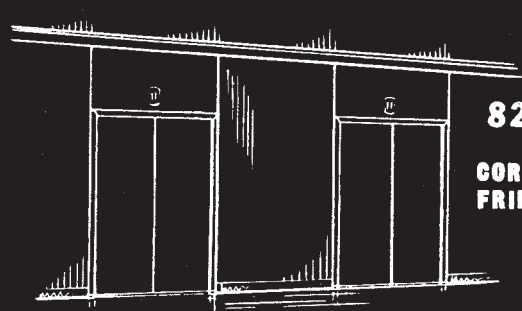

821
CORNICE
FRIEZE

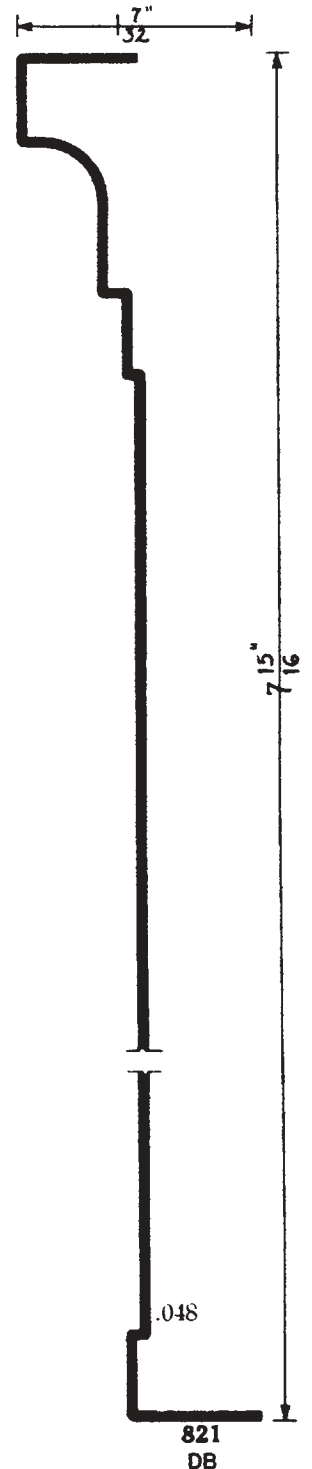
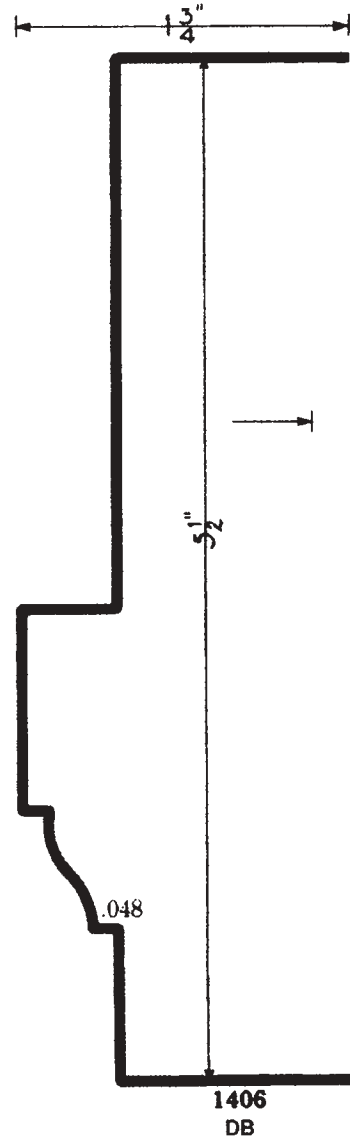
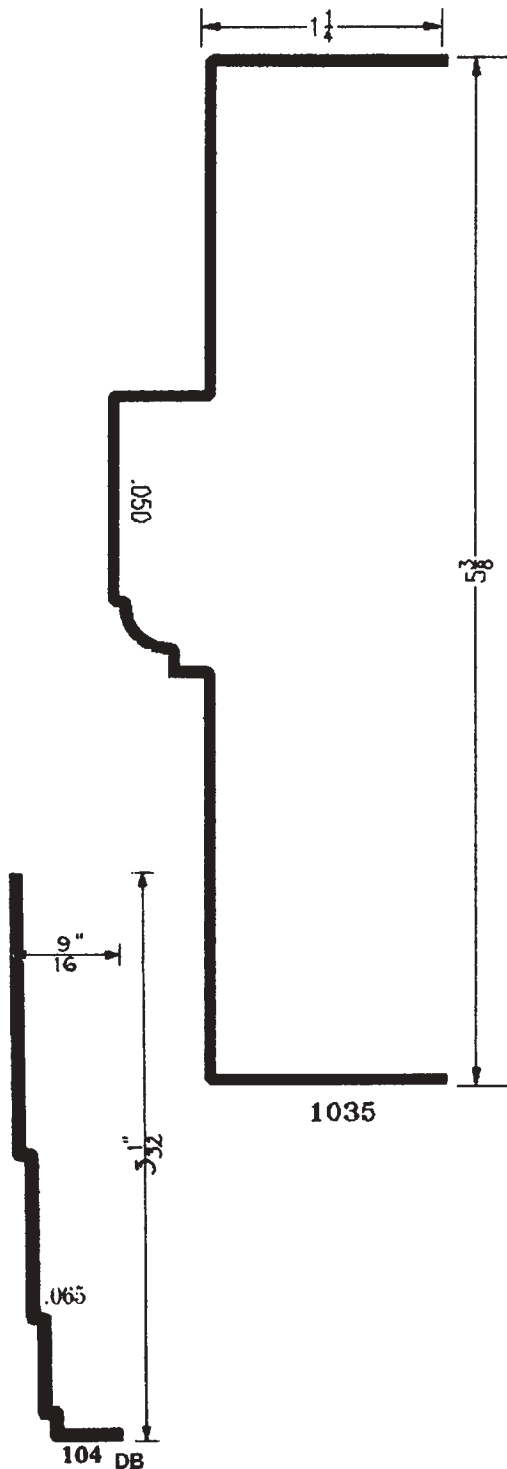

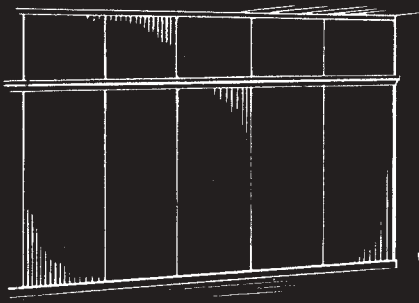

753

**PANEL
WALL
CORNICE**

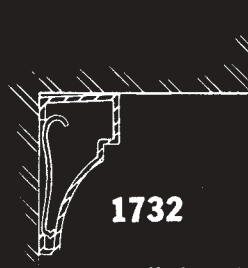

1732

TRIM FOR WALL OVERHANG

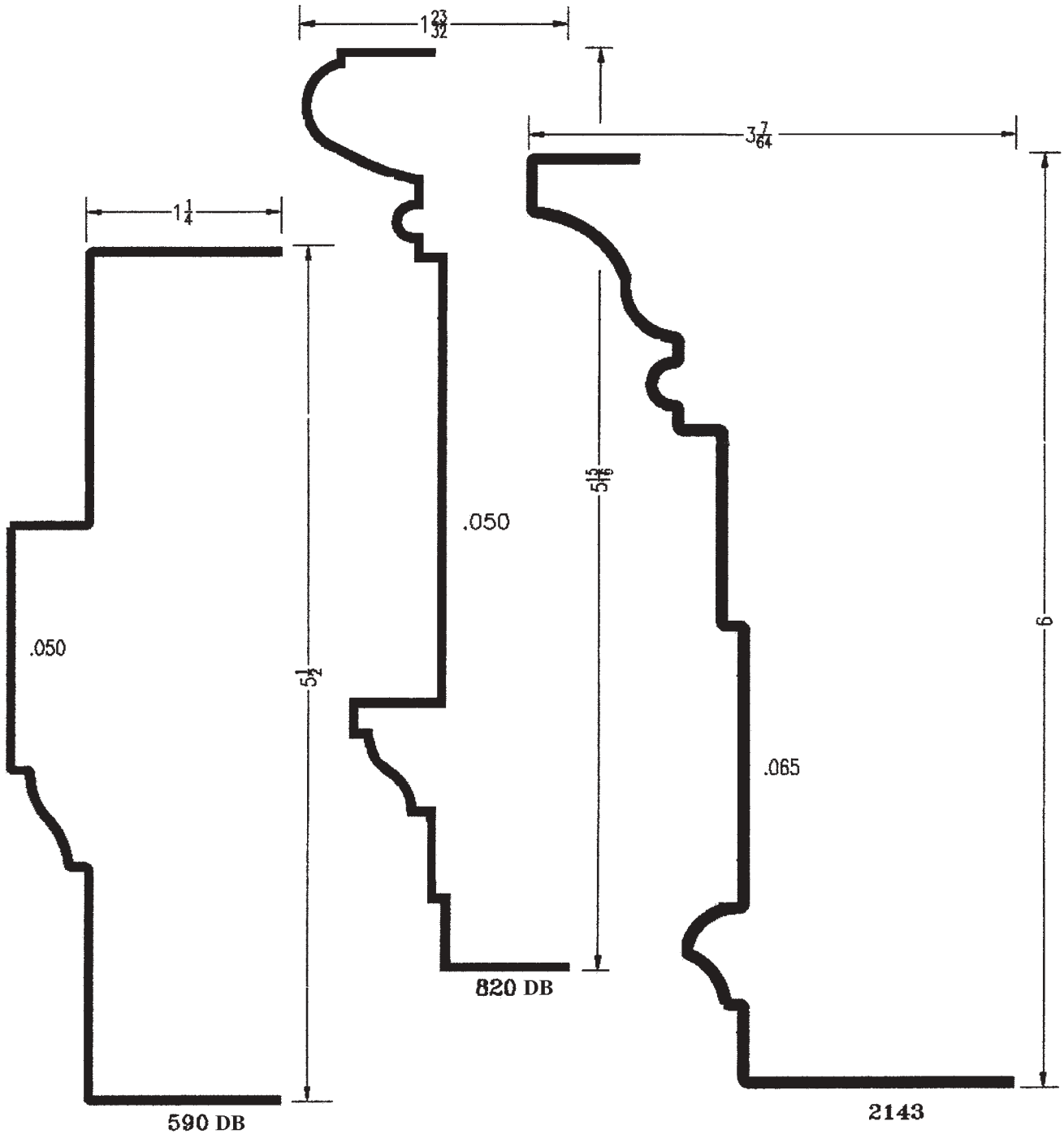

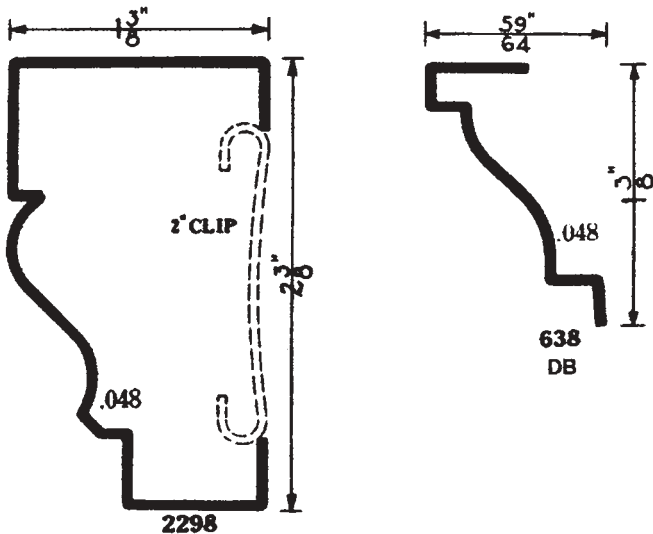
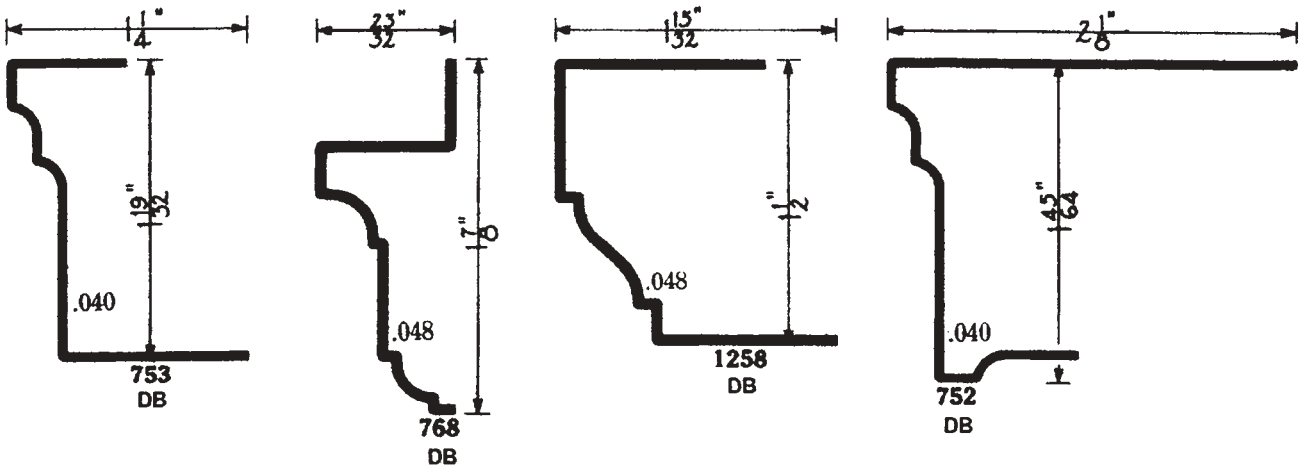
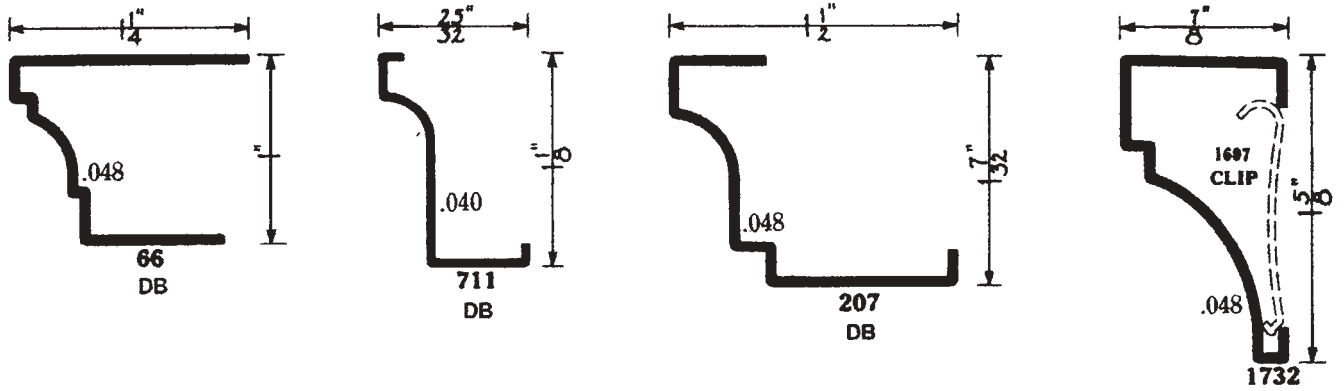
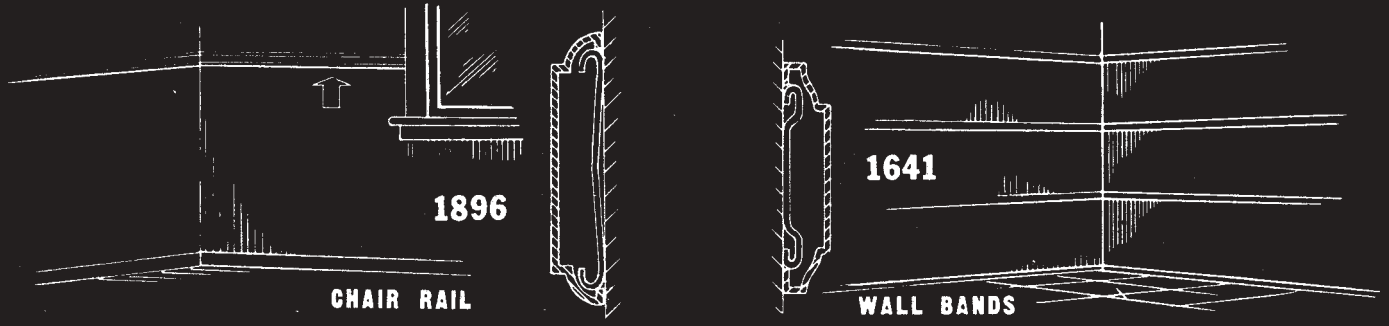



217
WINDOW
GUARD
RAIL

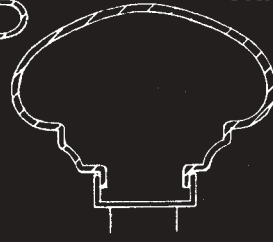

748 STAIR HAND RAIL

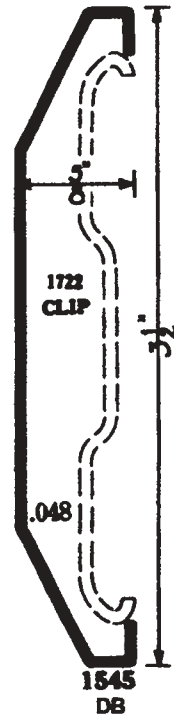
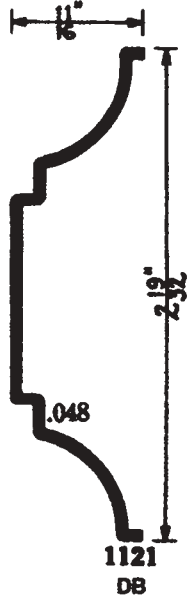
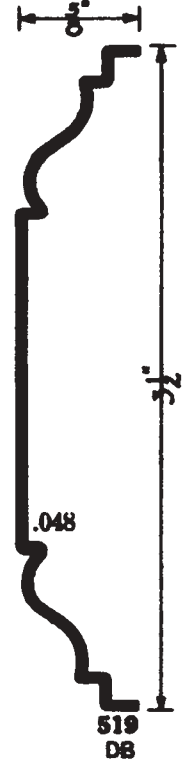

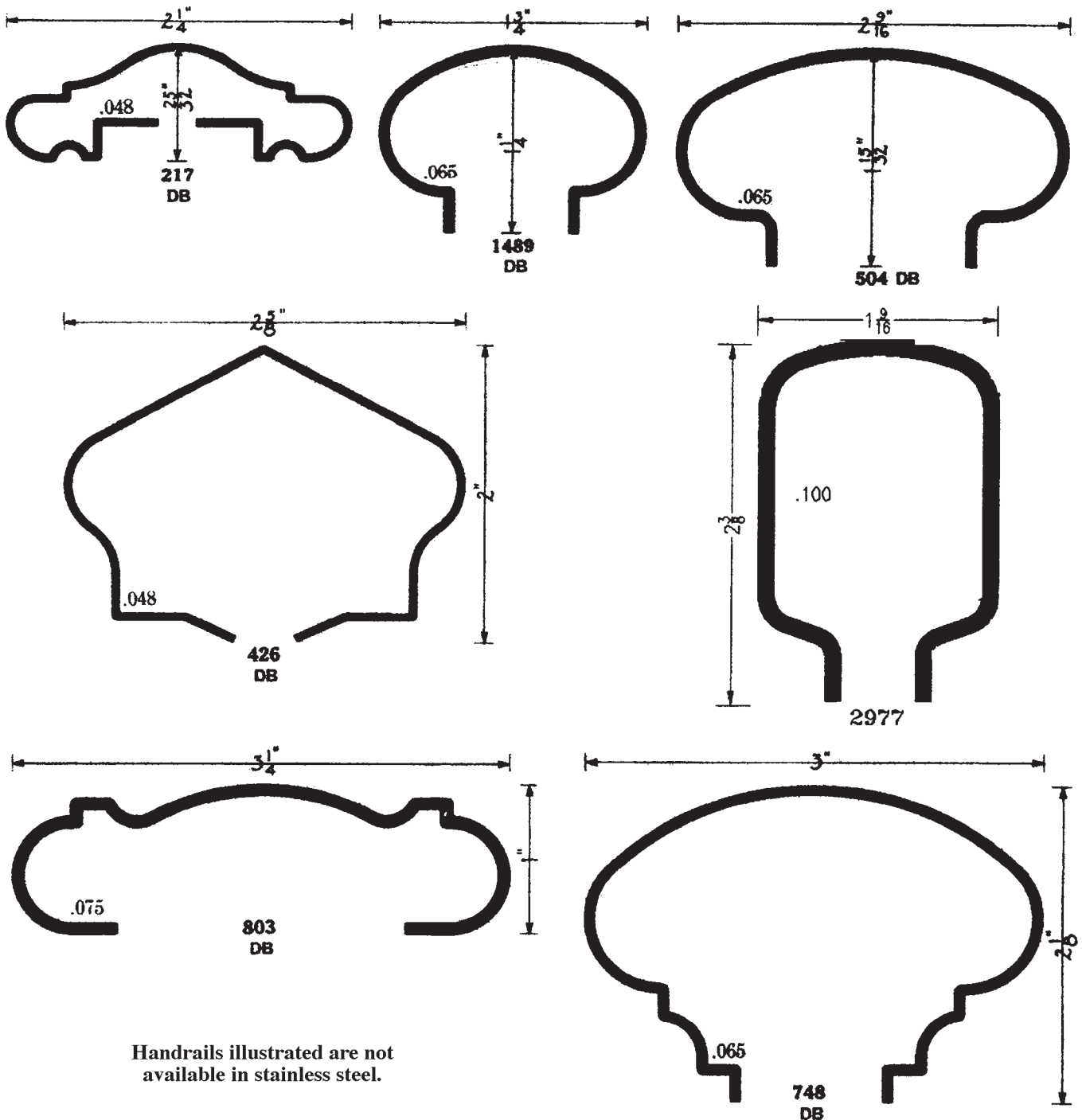
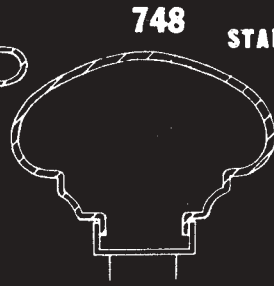

Handrails illustrated are not available in stainless steel.

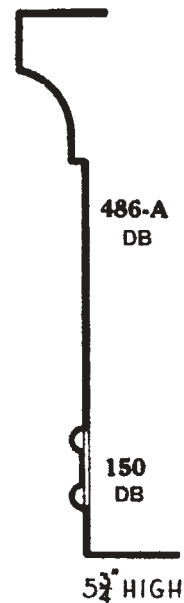
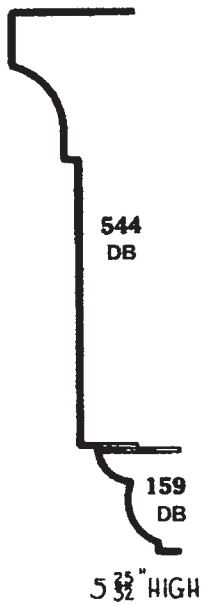
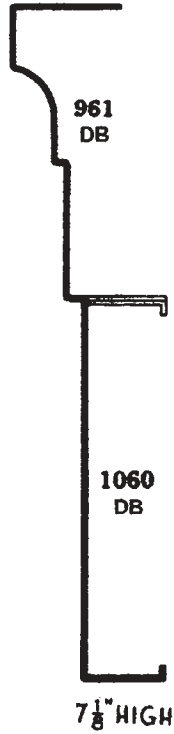
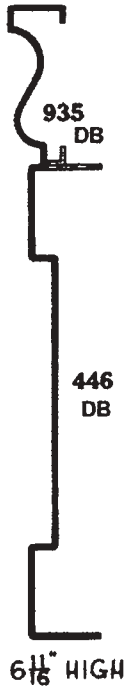
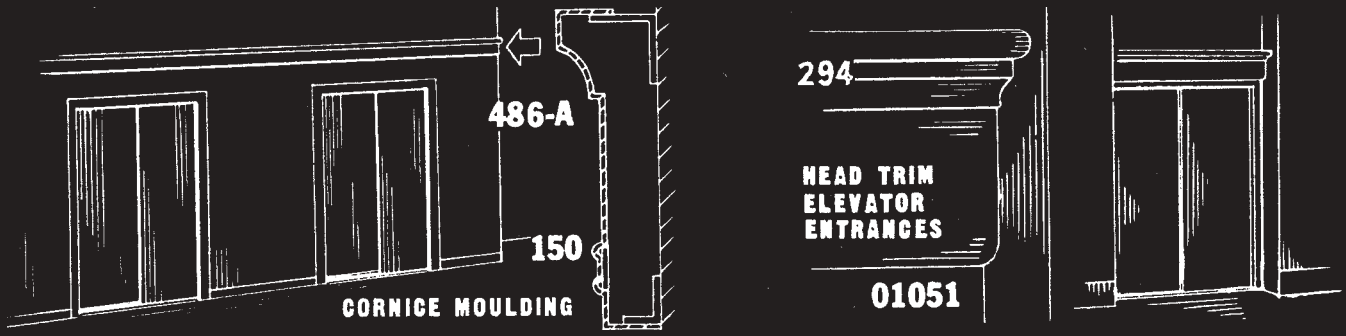

The Cornice Combinations as illustrated above are one-half actual size.