

SECTION FIVE

- TRIM PROFILES
- CURTAIN SLATS
- CORNER SHAPES
- HOOK SHAPES
- TONGUE & GROOVE SHAPES
- MISCELLANEOUS SHAPES

Trim Profiles

Profiles are used as finishing trim for cabinets, enclosures, joint covers and fascia trim.

Curtain Slats

Interlocking curtain slats are used for roll top desks and industrial roller curtains.

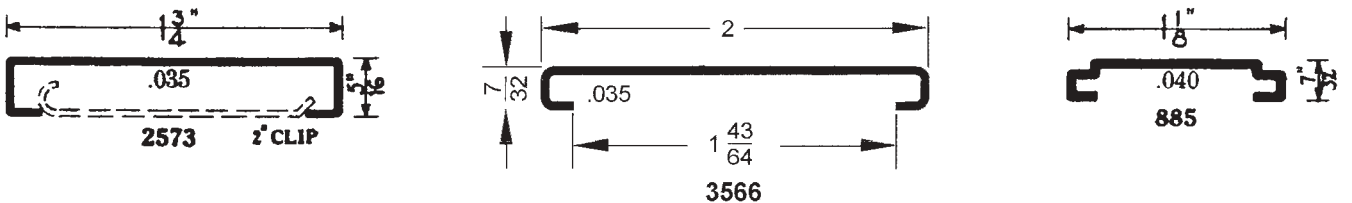
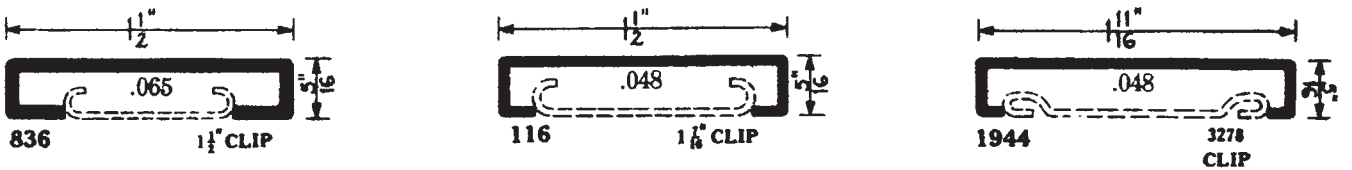
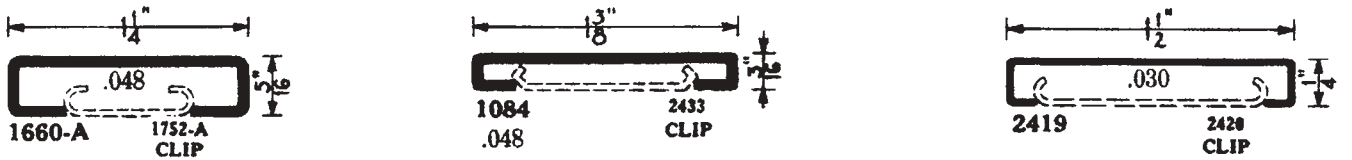
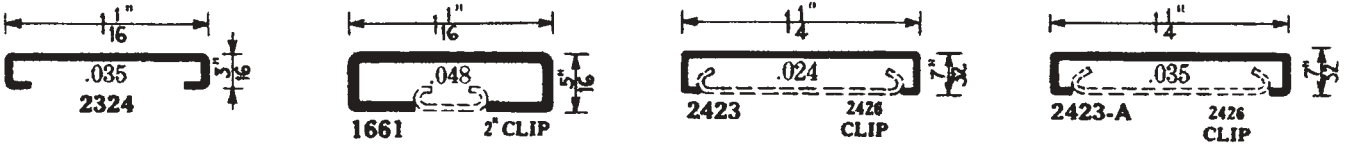
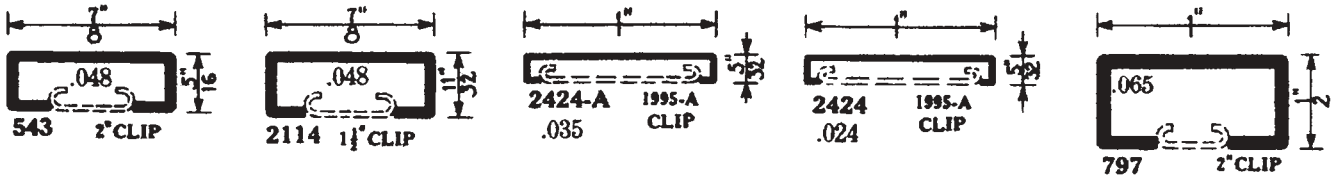
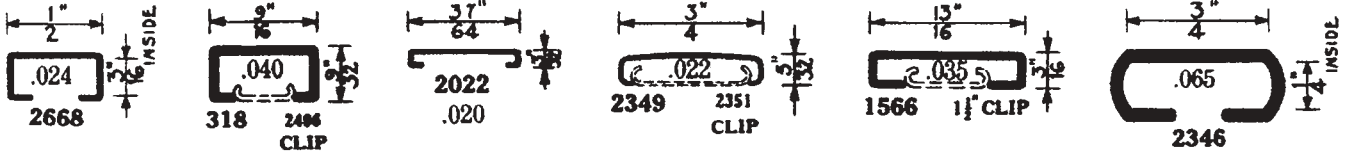
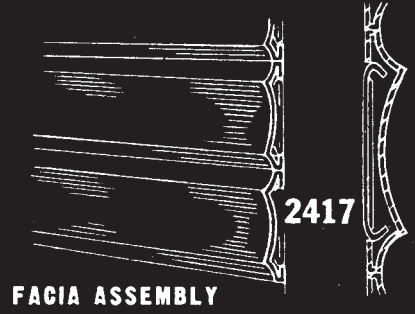
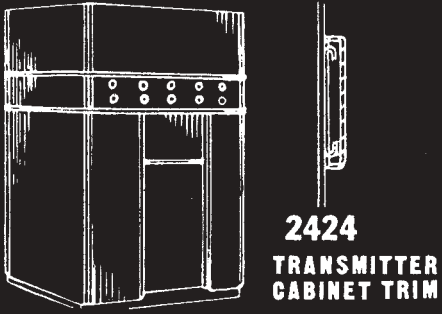

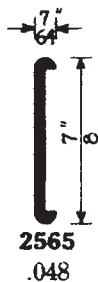
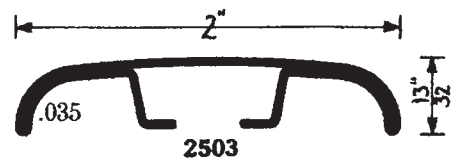
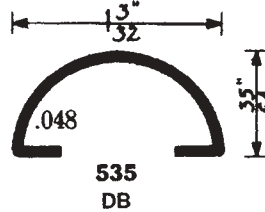
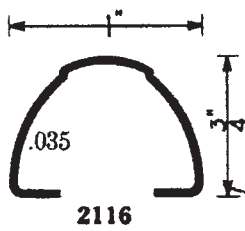
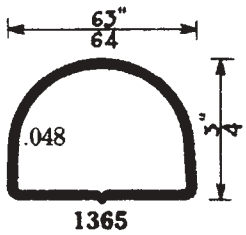
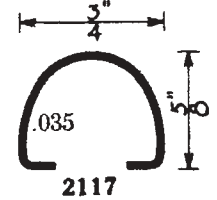
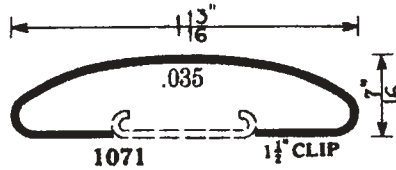
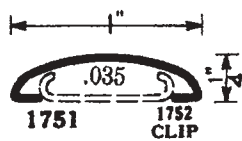
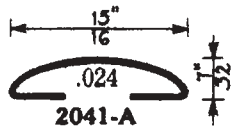
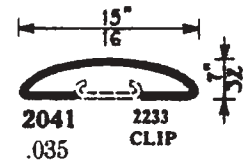
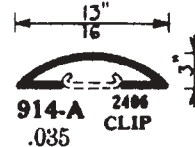
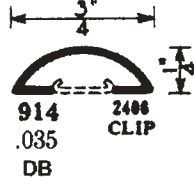
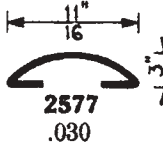
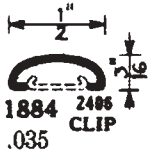
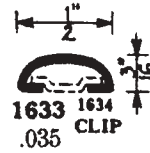
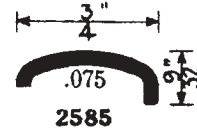
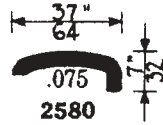
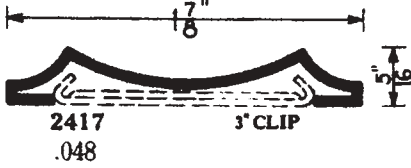
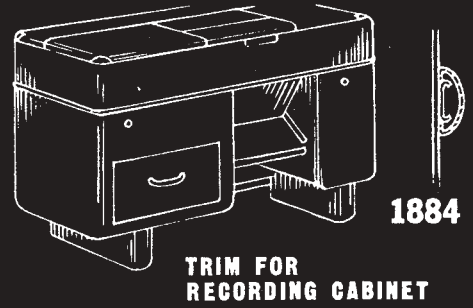
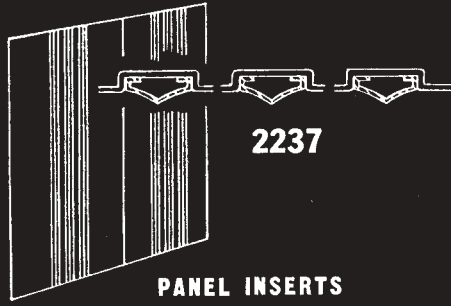

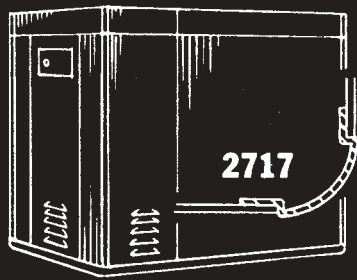

2717
TRIM — FURNACE HOUSING

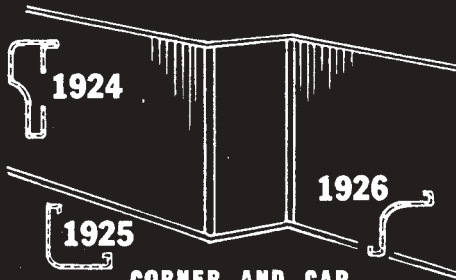

1924
1925
1926
CORNER AND CAP
TRIMS FOR PARTITION

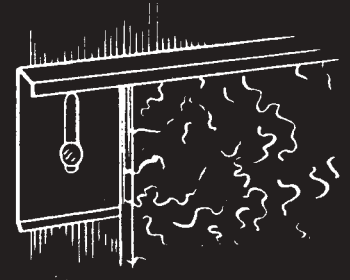

2243 LINOLEUM BINDING

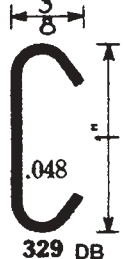
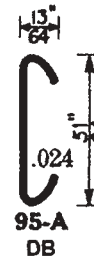
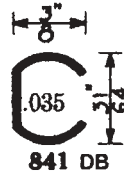
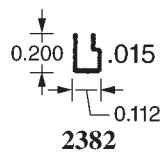
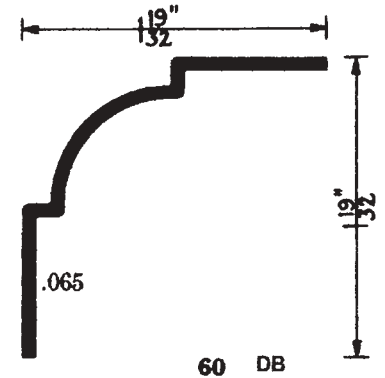
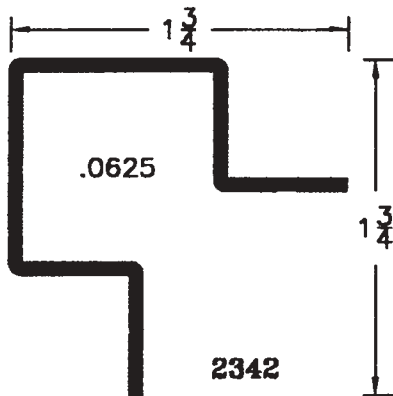
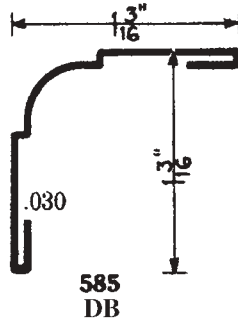
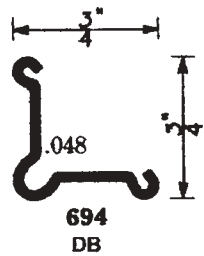
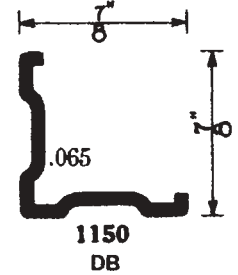
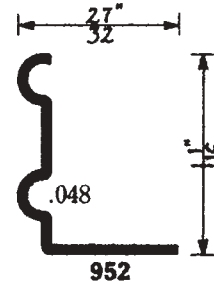
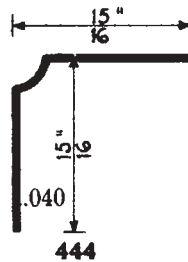
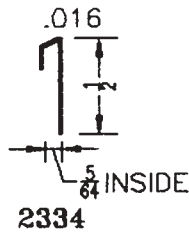
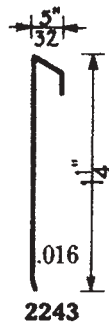
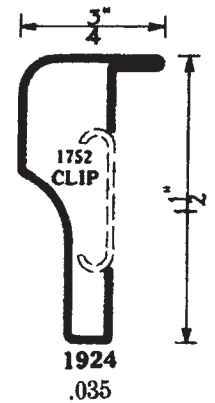
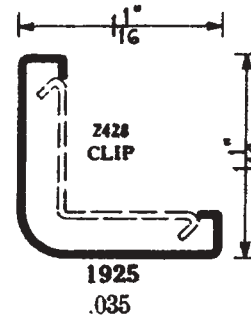
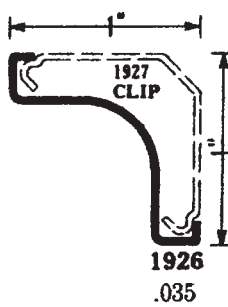
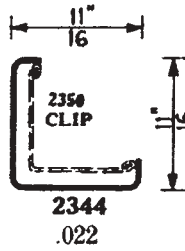
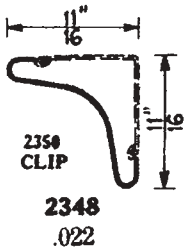

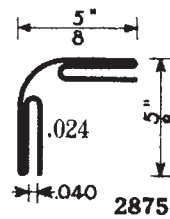
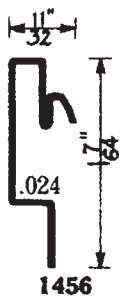
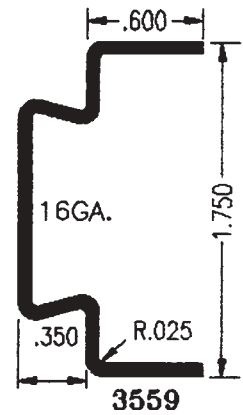
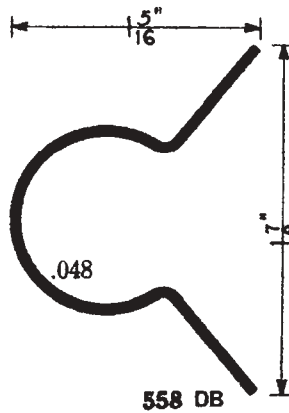
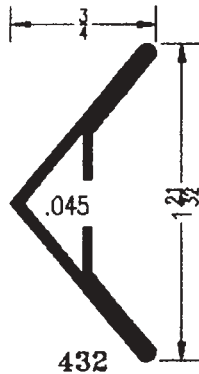
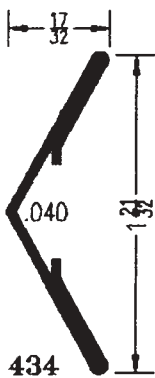
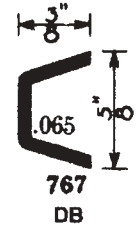
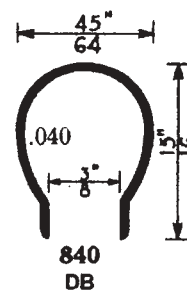
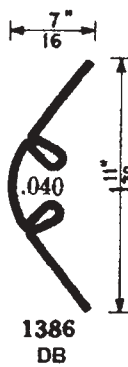
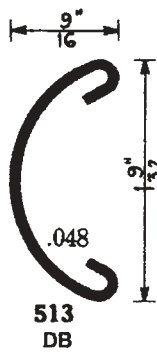
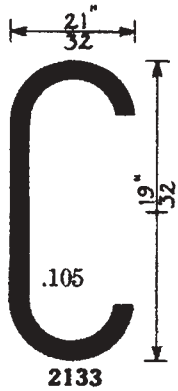
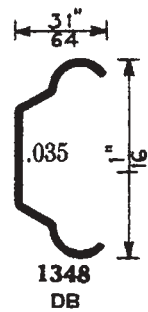
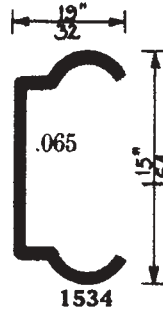
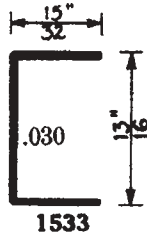
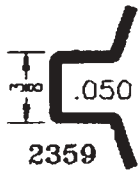

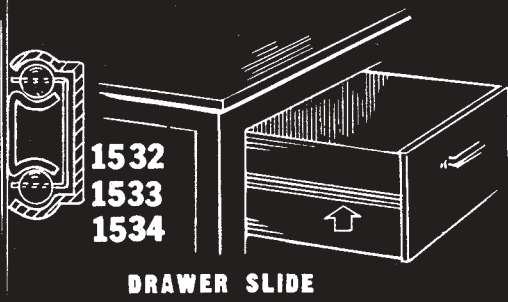

DRAWER SLIDE

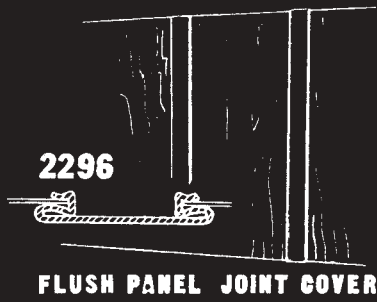

FLUSH PANEL JOINT COVER

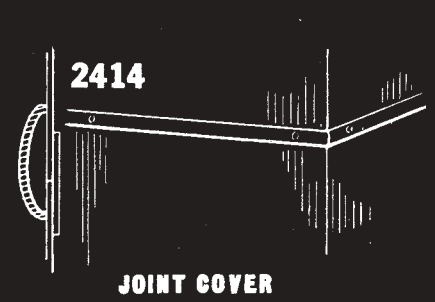

JOINT COVER

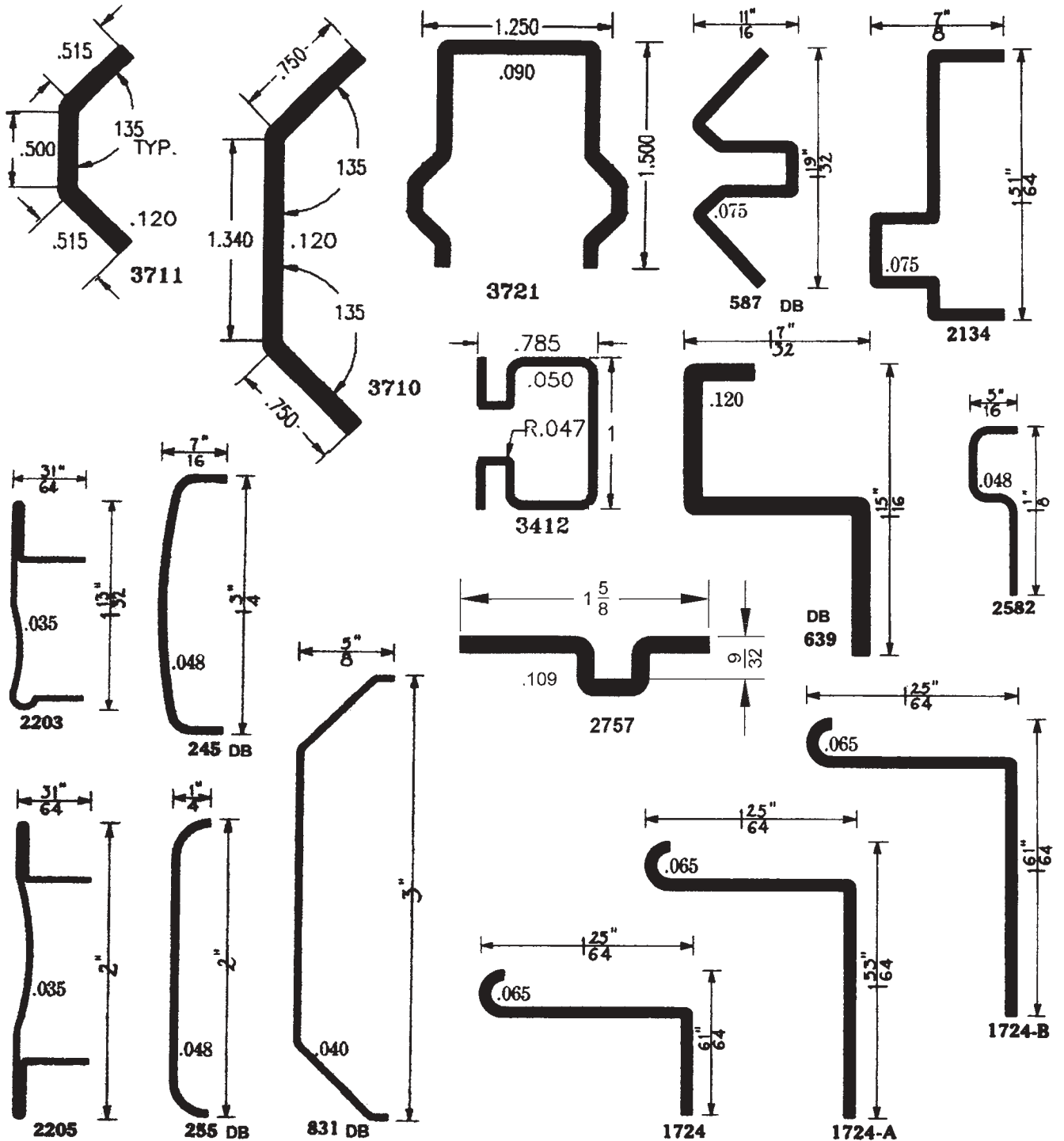

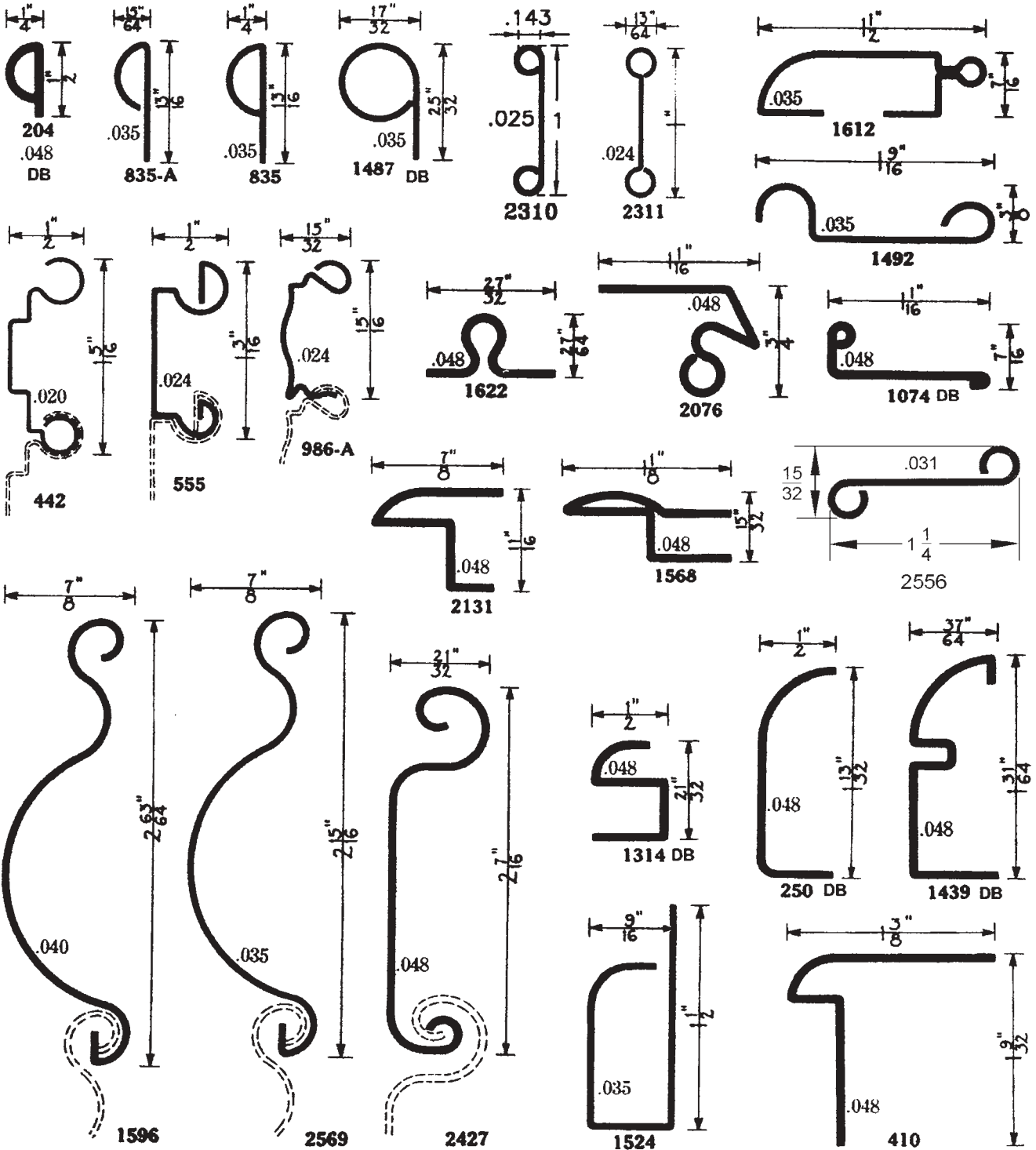
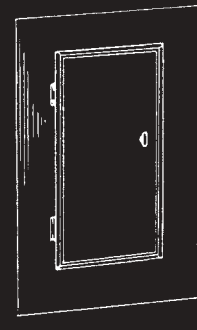
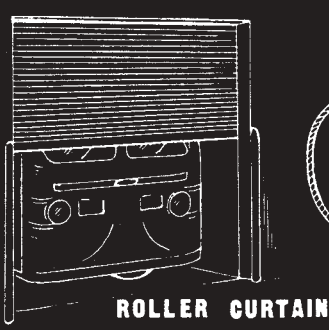

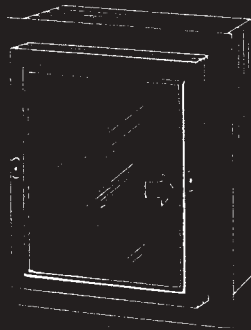

PANEL TRIM
METER CABINET

2394



1300

AIR CONDITIONING FRAME

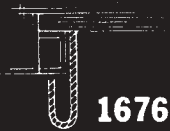
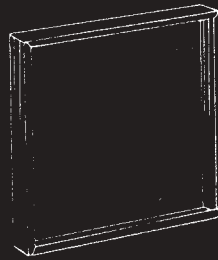

1676

CABINET
VISION PANEL
FRAME

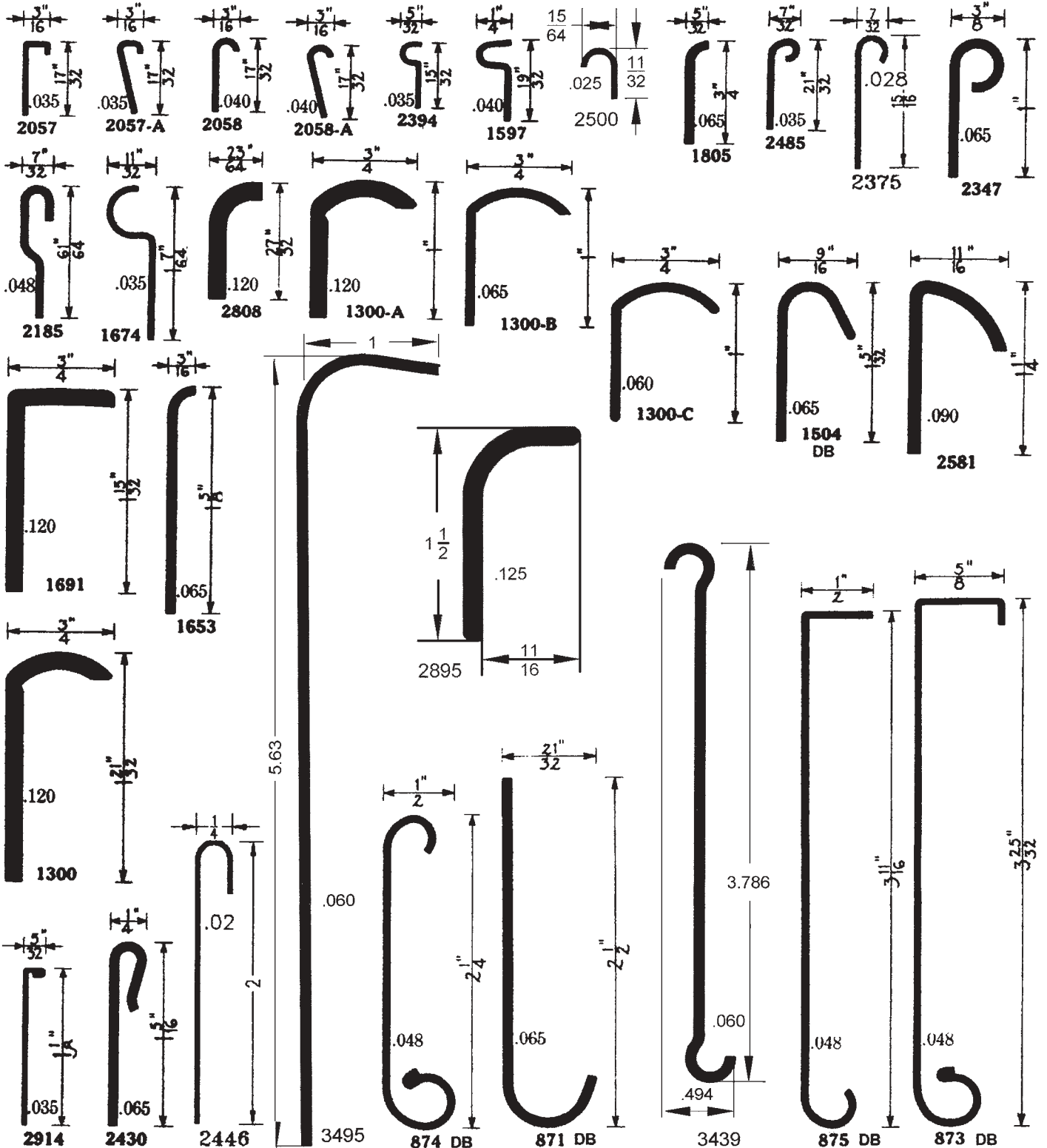

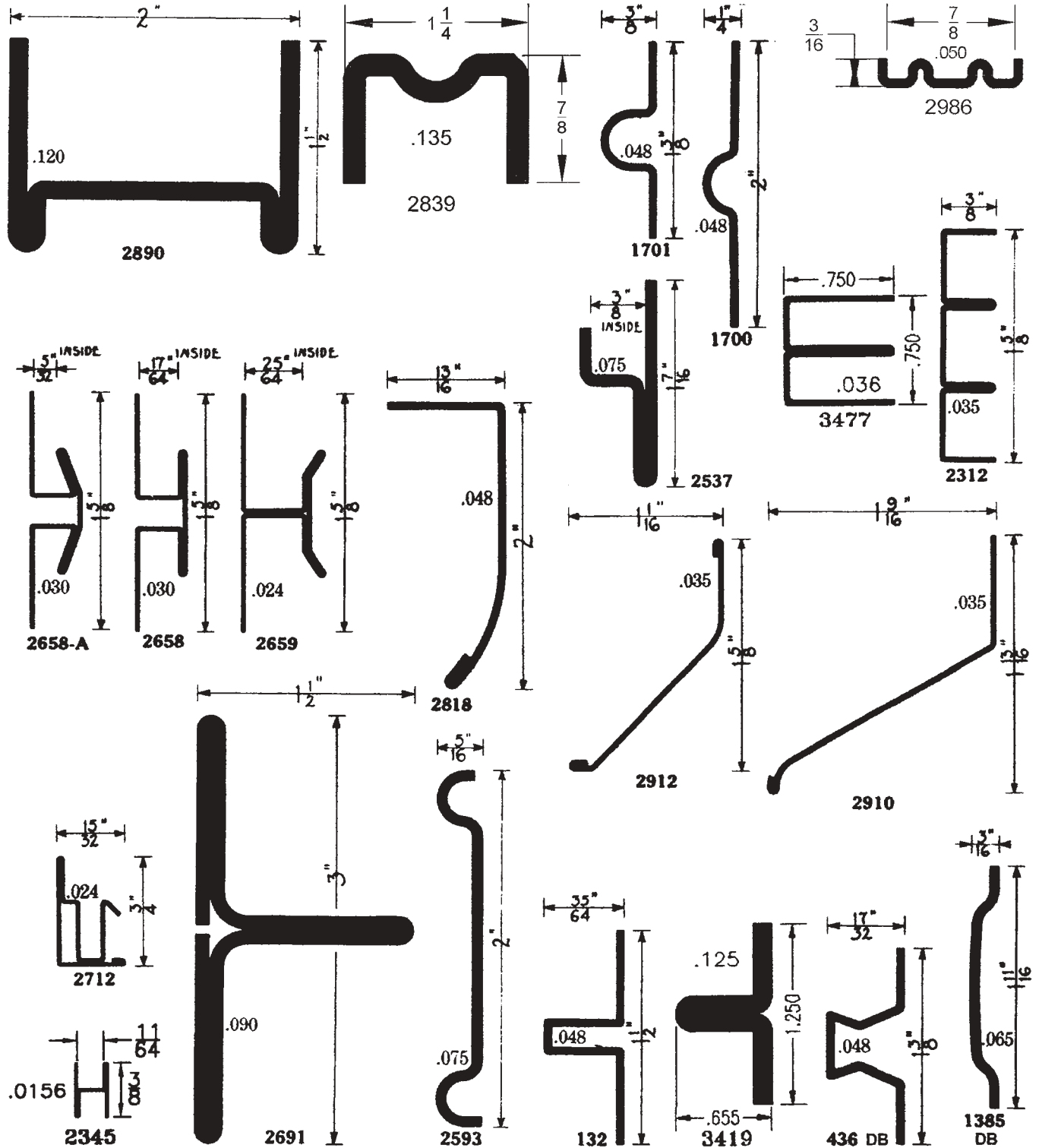
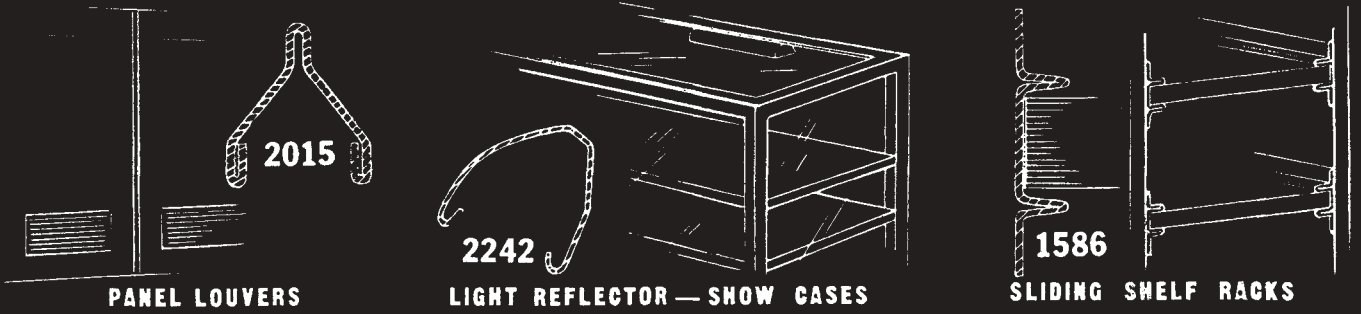

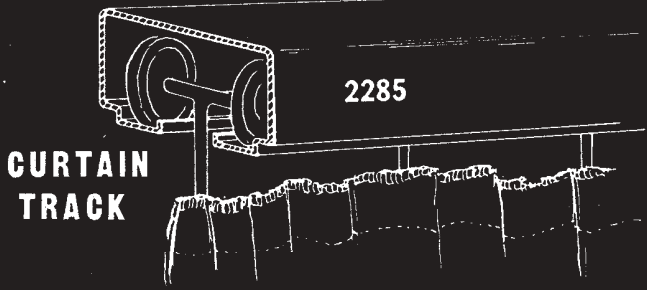

2285

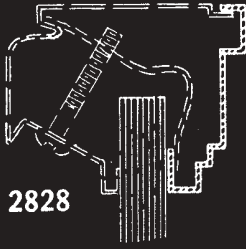

2828

2827

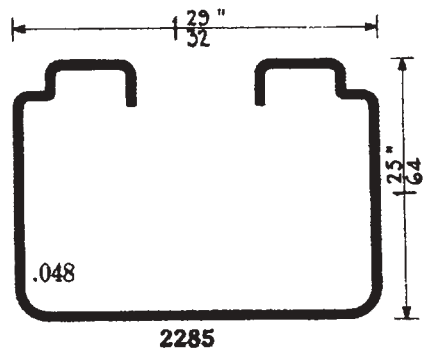
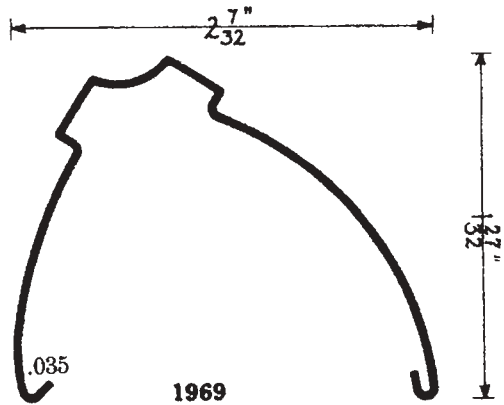
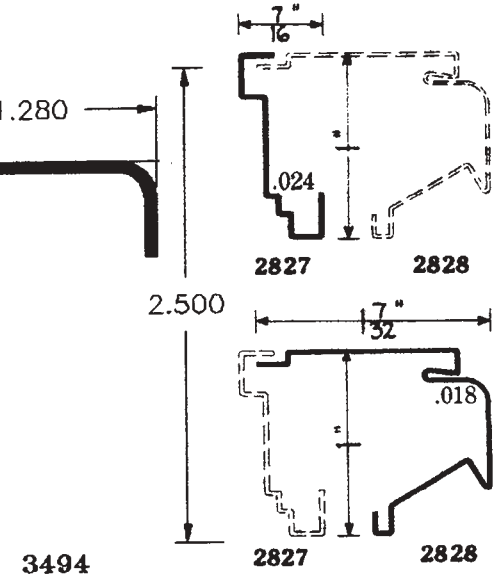
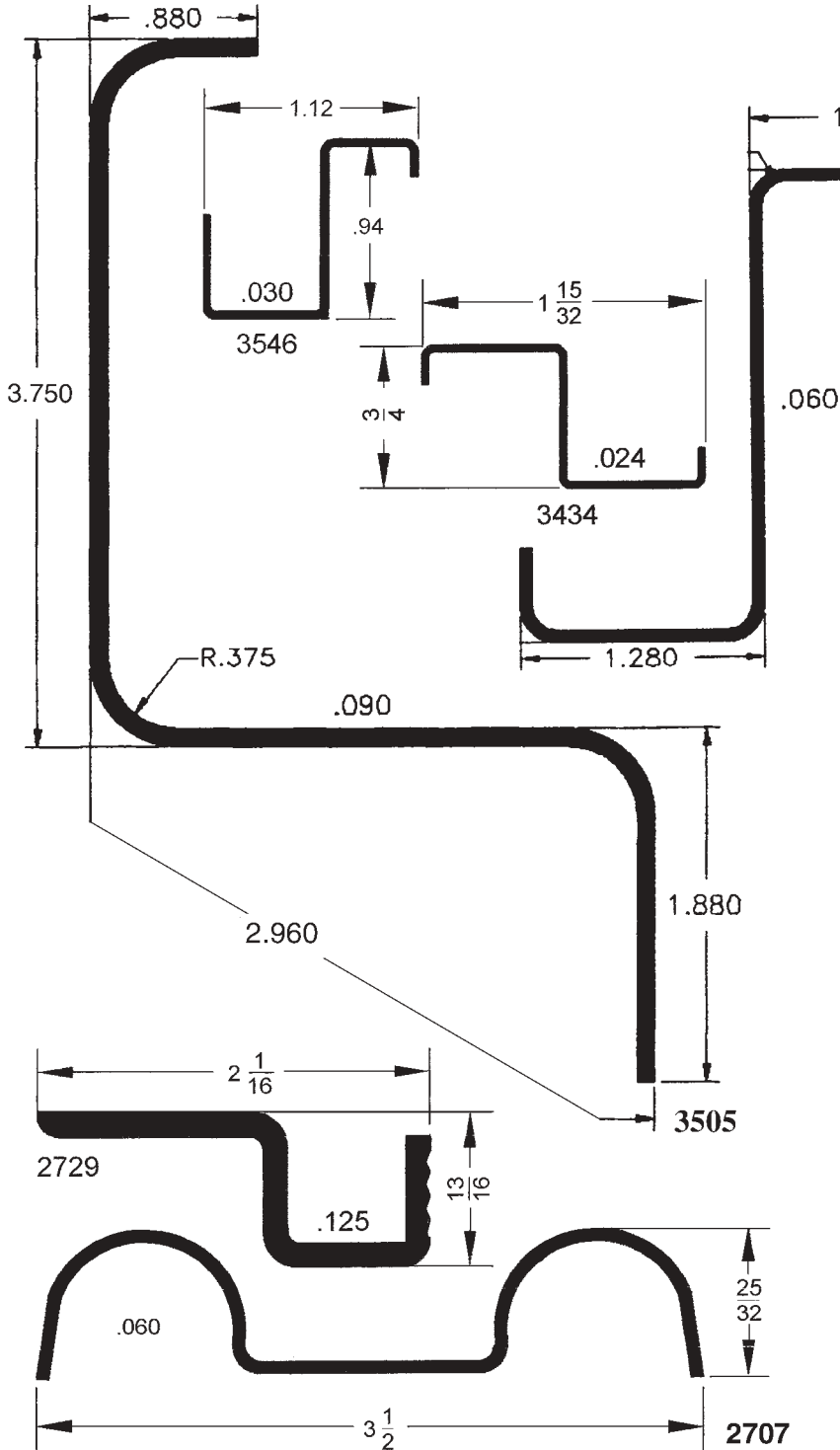

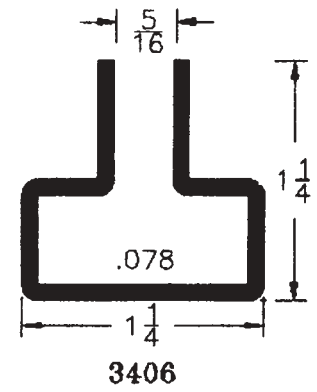
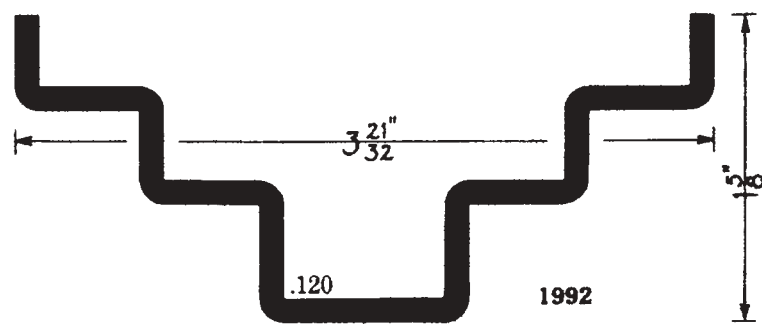
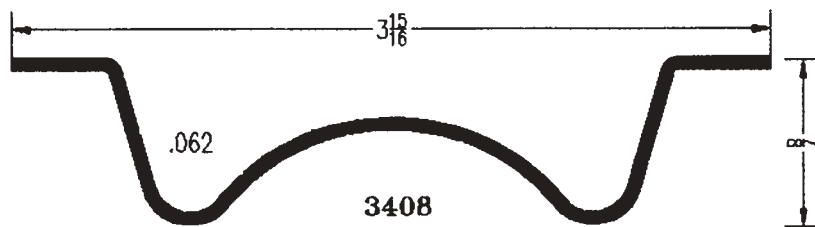
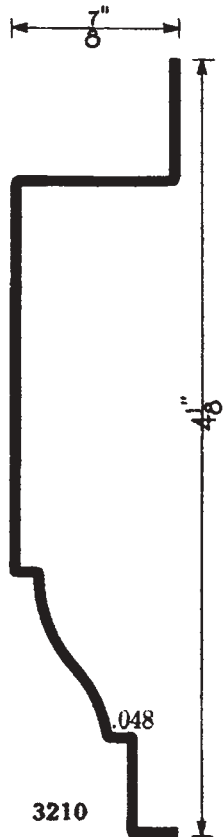
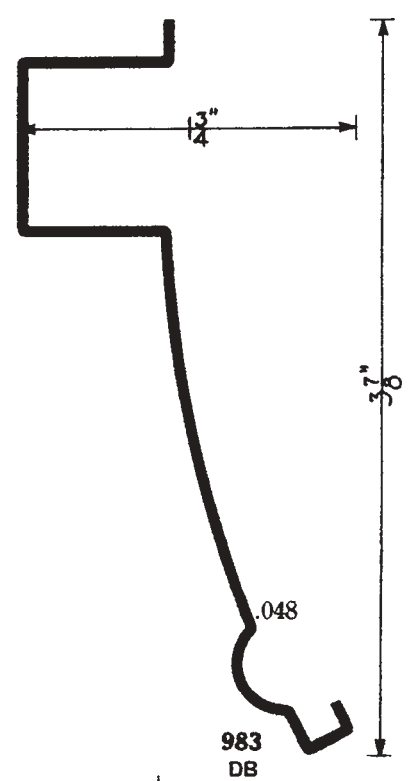
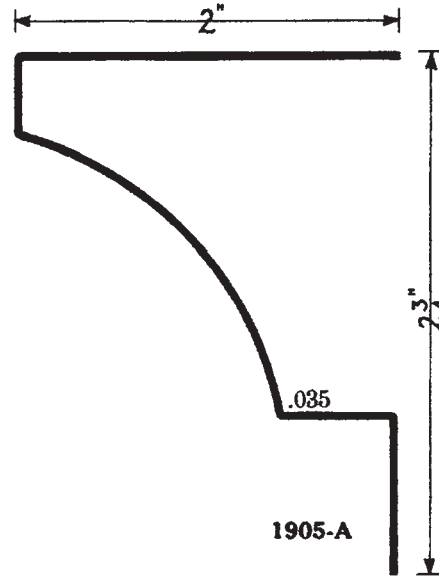
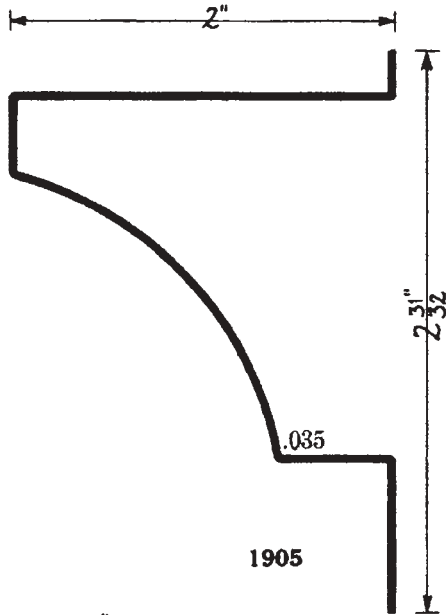
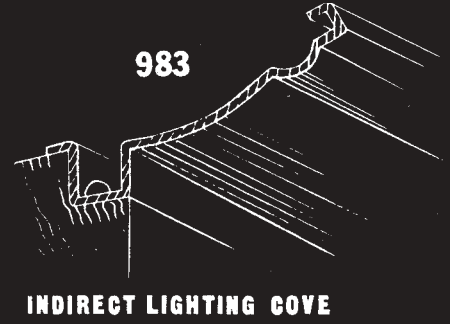
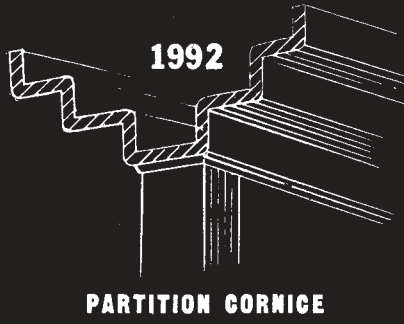
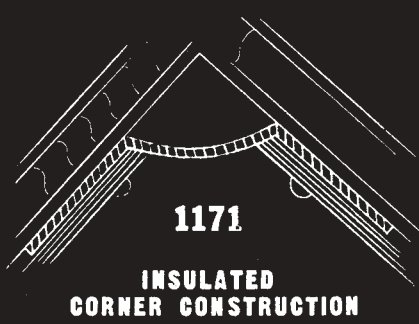

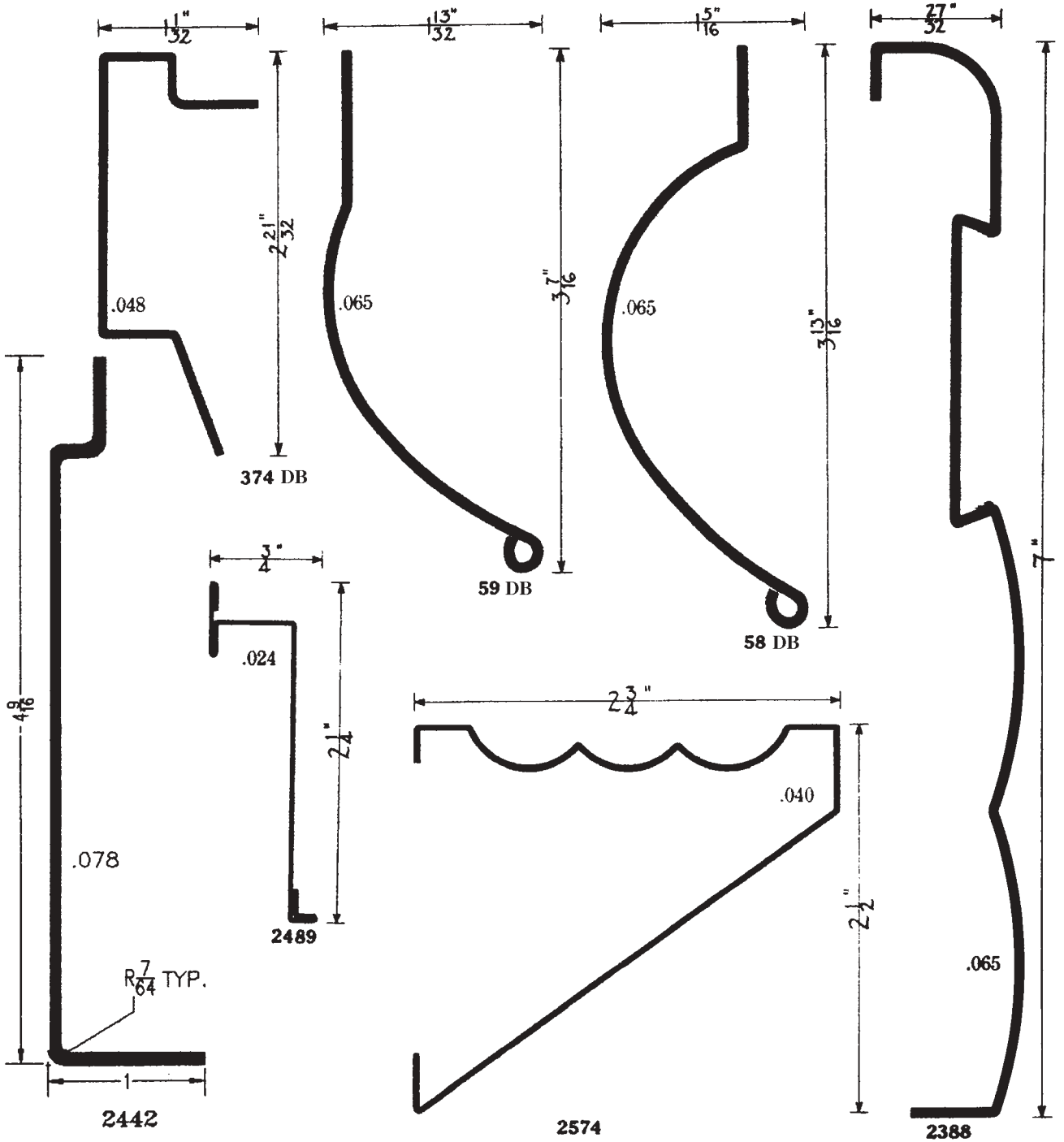
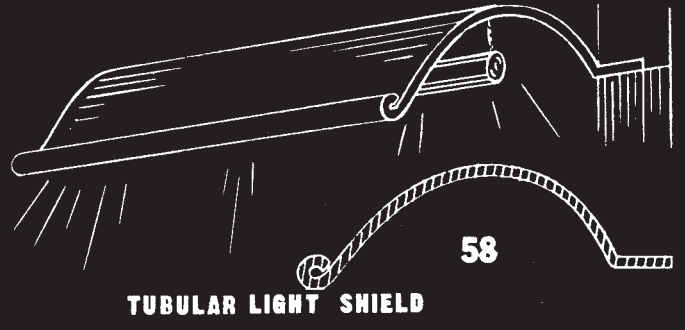
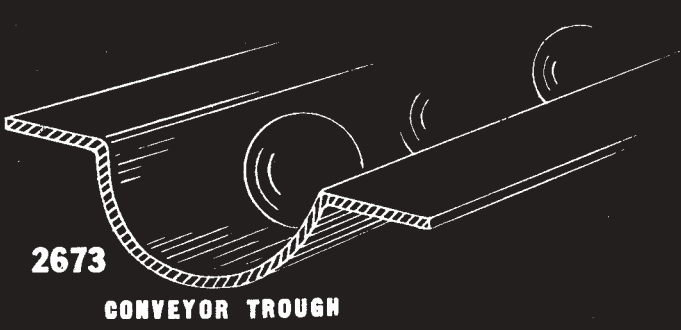

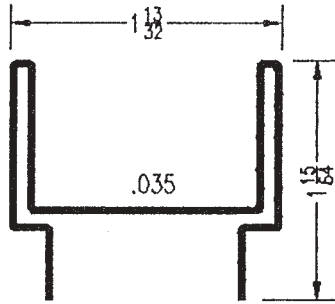
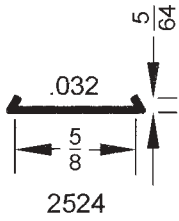
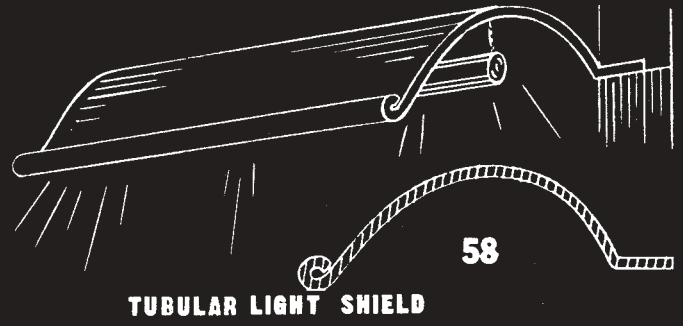
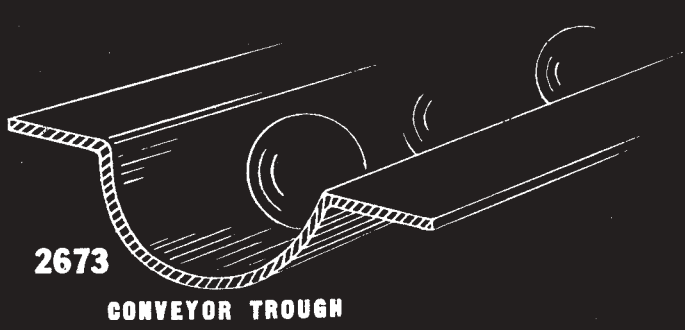

2141

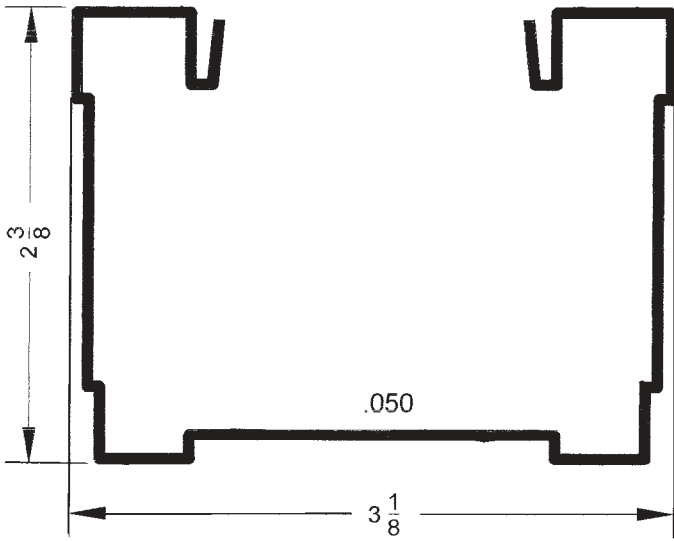
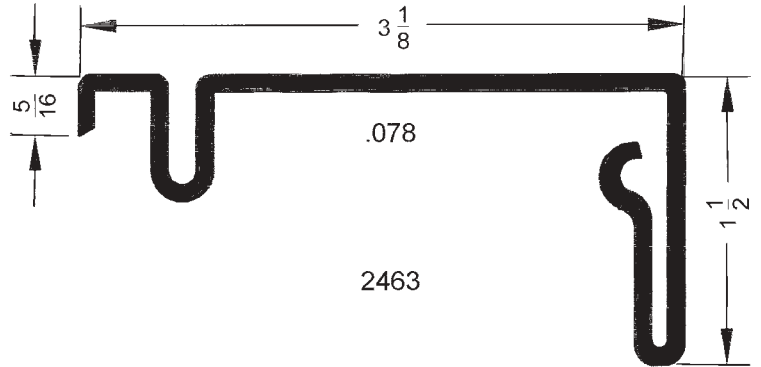

2137

Mates with 2134 (pg. 81)

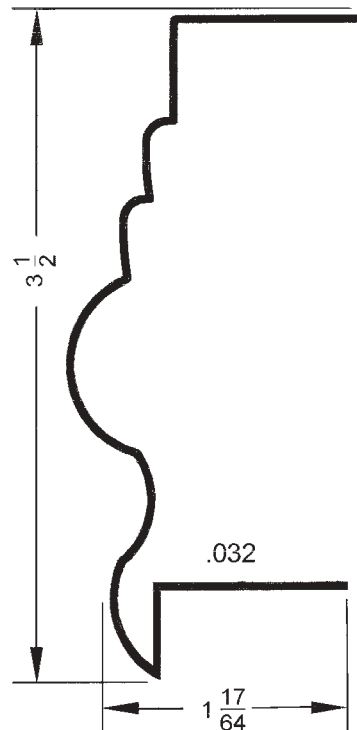

2313

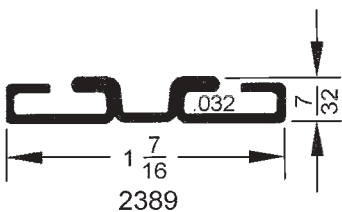

2389